

OLED DISPLAY MODULE

Product Specification

CUSTOMER	Standard	
PRODUCT NUMBER	DD-9616BE-3A	
CUSTOMER APPROVAL		Date

INTERNAL APPROVALS		
Product Mgr	Doc. Control	Electr. Eng
Bazile Peter	Bazile Peter	Luo Luo
Date: 05/03/11	Date: 05/03/11	Date: 28/03/11

TABLE OF CONTENTS

1	MAIN FEATURES	4
2	MECHANICAL SPECIFICATION	5
2.1	MECHANICAL CHARACTERISTICS	5
2.2	MECHANICAL DRAWING	6
3	ELECTRICAL SPECIFICATION.....	7
3.1	ABSOLUTE MAXIMUM RATINGS	7
3.2	ELECTRICAL CHARACTERISTICS	8
3.3	INTERFACE PIN ASSIGNMENT	9
3.4	BLOCK DIAGRAM	10
4	OPTICAL SPECIFICATION.....	13
4.1	OPTICAL CHARACTERISTICS.....	13
5	FUNCTIONAL SPECIFICATION	14
5.1	COMMANDS	14
5.2	POWER UP/DOWN SEQUENCE.....	14
5.3	RESET CIRCUIT.....	15
5.4	ACTUAL APPLICATION EXAMPLE.....	16
6	PACKAGING AND LABELLING SPECIFICATION.....	18
6.1	LABELLING & MARKING.....	19
7	QUALITY ASSURANCE SPECIFICATION	19
7.1	CONFORMITY	19
7.2	DELIVERY ASSURANCE	19
7.3	DEALING WITH CUSTOMER COMPLAINTS	24
8	RELIABILITY SPECIFICATION	25
8.1	RELIABILITY TESTS	25
8.2	LIFE TIME.....	25
8.3	FAILURE CHECK STANDARD	25
9	HANDLING PRECAUTIONS.....	26
9.1	HANDLING PRECAUTIONS	26
9.2	STORAGE PRECAUTIONS.....	27
9.3	OTHER PRECAUTIONS.....	28
9.4	PRECAUTIONS WHEN DISPOSING OF THE OEL DISPLAY MODULES	28
10	SUPPORTED ACCESSORIES	29
10.1	DUO KIT.....	29
10.2	TRANSITION BOARD CARD	29
10.3	CONNECTOR BOARD CARD.....	29
10.4	CONNECTORS	29

Product No.	DD-9616BE-3A	REV. A

Page	2 / 29
------	--------

REVISION RECORD

Rev.	Date	Page	Chapt.	Comment	ECR no.
A	05 Mar 11			First Issue	

Product No.	DD-9616BE-3A	REV. A

Page	3 / 29
------	--------

1 MAIN FEATURES

ITEM	CONTENTS
Display Format	96 x 16 Dots
Overall Dimensions(W*H*T)	29.10×9.20× 1.30 mm
Active Area(W*H)	21.104 × 3.504 mm
Viewing Area(W*H)	23.104 x 5.504 mm
Display Mode	Passive Matrix
Display Colour	Blue Colour
Driving Method	1 / 16 duty
Driver IC	SSD1306
Operating temperature	-40°C ~ +70°C
Storage temperature	-40°C ~ +80°C

Product No.	DD-9616BE-3A	REV. A

Page	4 / 29
------	--------

2 MECHANICAL SPECIFICATION

2.1 MECHANICAL CHARACTERISTICS

ITEM	CHARACTERISTIC	UNIT
Display Format	96 x 16	Dots
Overall Dimensions	29.10×9.20× 1.30	mm
Viewing Area	23.104 x 5.504	mm
Active Area	21.104 × 3.504	mm
Dot Size	0.204 × 0.204	mm
Dot Pitch	0.22 × 0.22	mm
Weight	0.72	g
IC Controller/Driver	SSD1306	

Product No.	DD-9616BE-3A	REV. A

Page	5 / 29
------	--------

2.2 MECHANICAL DRAWING

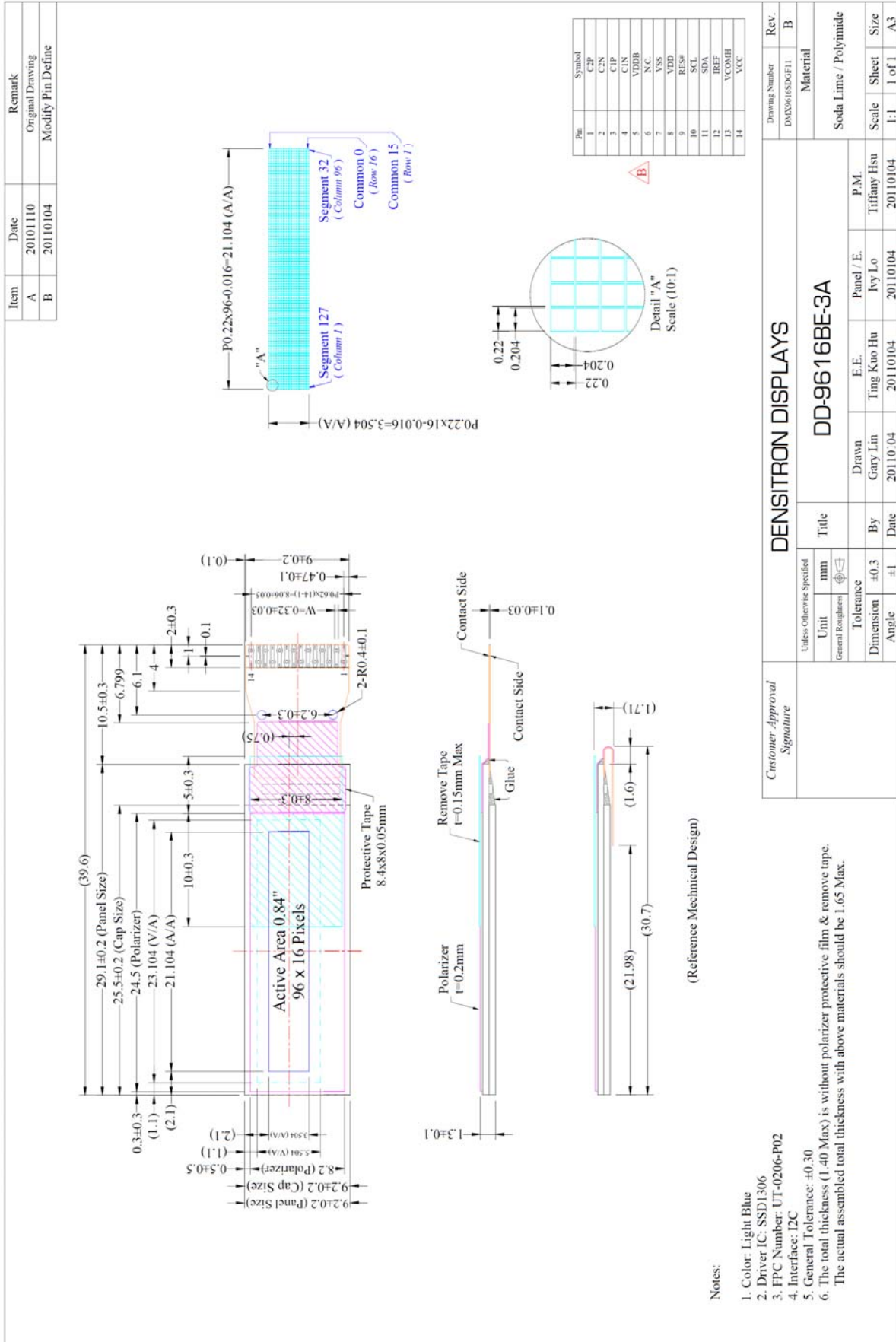

Product No.	DD-9616BE-3A	REV. A
-------------	--------------	--------

Page	6 / 29
------	--------

3 ELECTRICAL SPECIFICATION

3.1 ABSOLUTE MAXIMUM RATINGS

VSS = 0 V, Ta = 25 °C

Item	Symbol	Min	Max	Unit	Note
Supply Voltage for Operation	V _{DD}	-0.3	4	V	Note 1, 2
Supply Voltage for Display	V _{CC}	0	11	V	Note 1, 2
Supply Voltage for DC/DC	V _{DDB}	-0.3	5	V	Note 1, 2
Operating Temperature	Top	-40	70	°C	
Storage Temperature	Tstg	-40	85	°C	Note 3
Static Electricity	Be sure that you are grounded when handling displays.				

Note 1: All the above voltages are on the basis of “VSS=0V”.

Note 2: When this module is used beyond above absolute maximum ratings, permanent damage to the module may occur. Also for normal operations it's desirable to use this module under the conditions according to Section 3.2 “Electrical Characteristics” and section 4 “optical characteristic. If this module is used beyond these conditions the module may malfunction and the reliability could deteriorate.

Note 2: The defined temperature ranges do not include the polarizer. The maximum withstood temperature of the polarizer should be 80°C.

3.2 ELECTRICAL CHARACTERISTICS

3.2.1 DC Characteristics

Characteristics	Symbol	Conditions	Min	Typ	Max	Unit
Supply Voltage for Logic	V _{DD}		1.65	2.8	3.3	V
Supply Voltage for Display	V _{CC}	Note 1	7.0	7.25	7.5	V
Supply Voltage for DC/DC	V _{BAT}	Internal DC/DC	3.3	-	4.2	V
Supply Voltage for Display (Generated by Internal DC/DC)	V _{CC}	Internal DC/DC	7.0		7.5	
High Level Input	V _{IH}	I _{out} =100μA,3.3 MHz	0.8xV _{DD}	-	V _{DD}	V
Low Level Input	V _{IL}	I _{out} =100μA,3.3 MHz	0	-	0.2xV _{DD}	V
High Level Output	V _{OH}	I _{out} =100μA,3.3 MHz	0.9xV _{DD}	-	V _{DD}	V
Low Level Output	V _{OL}	I _{out} =100μA,3.3 MHz	0	-	0.1xV _{DD}	V
Operating Current for VDD	I _{DD}		-	180	300	μA
Operating Current for VCC (VCC Supplied Externally)	I _{CC}	Note 2		2.0	2.5	mA
		Note 3		2.7	3.4	
		Note 5		4.5	5.6	
Operating Current for VBAT(VCC Generated by Internal DC/DC)	I _{BAT}	Note 2		6.7	8.4	mA
		Note 3		9.0	11.3	
		Note 5		14.6	18.3	
Sleep Mode Current for VCI	I _{DD, SLEEP}	-	-	1	5	μA
Sleep Mode Current for VCC	I _{CC, SLEEP}	-	-	2	10	μA

Note 1: Brightness (L_{br}) and Supply Voltage for Display (V_{CC}) is subject to the change of the panel characteristics and the customer's request.

Note 2: V_{DD}= 2.8V, V_{CC} = 7.25V, 30% Display area turned on.

Note 3: V_{DD}= 2.8V, V_{CC} = 7.25V, 50% Display area turned on.

Note 4: V_{DD} = 2.8V, V_{CC} = 7.25V, 100% Display area turned on

Product No.	DD-9616BE-3A	REV. A

Page	8 / 29
------	--------

3.3 INTERFACE PIN ASSIGNMENT

No.	Symbol	I/O	Function
1	C2P	I	<p>Positive Terminal of the Flying Inverting Capacitor Negative Terminal of the Flying Boost Capacitor The charge-pump capacitors are required between the terminals. They must be floating when the converter is not used.</p>
2	C2N	I	
3	C1P	I	
4	C1N	I	
5	VDDB	P	<p>Power Supply for DC/DC Converter Circuit This is the power supply pin for the internal buffer of the DC/DC voltage converter. It must be connected to external source when the converter is used. It should be connected to VDD when the converter is not used.</p>
6	N.C	-	<p>Reserved Pin The N.C. pin between function pins are reserved for compatible and flexible design. It must be floated.</p>
7	VSS	P	<p>Ground of Logic Circuit This is a ground pin. It acts as a reference for the logic pins. The OEL driving voltages and the analogue circuits. It must be connected to external ground.</p>
8	VDD	P	<p>Power Supply for Logic This is a voltage supply pin. It must be connected to external source</p>
9	RES#	I	<p>Power Reset for Controller and Driver This pin is reset signal input.. When the pin is low, initialization of the chip is executed.</p>
10	SCL	I	<p>I2C Bus Clock Signal The transmission if information in the I2C bus is following a clock signal. Each transmission of data bit is taken place during a single clock period of this pin</p>
11	SDA	I/O	<p>I2C Bus Data Signal This pin acts as a communication channel between the transmitter and the receiver.</p>
12	IREF	I	<p>Current Reference for Brightness Adjustment This pin is segment current reference pin. A resistor should be connected between this pin and VSS. Set the current lower than 12.5µA.</p>
13	VCOMH	O	<p>Voltage Output High Level for COM Signal This pin is the input pin for the voltage output high level for COM signals. A capacitor should be connected between this pin and VSS.</p>
14	VCC	P	<p>Power Supply for OEL Panel This is the most positive voltage supply pin of the chip. It must be connected to external source. A stabilizing capacitor should be connected between this pin and VSS when the converter is used.</p>

Product No.	DD-9616BE-3A	REV. A

Page	9 / 29
------	--------

3.4 BLOCK DIAGRAM

3.4.1 External VCC

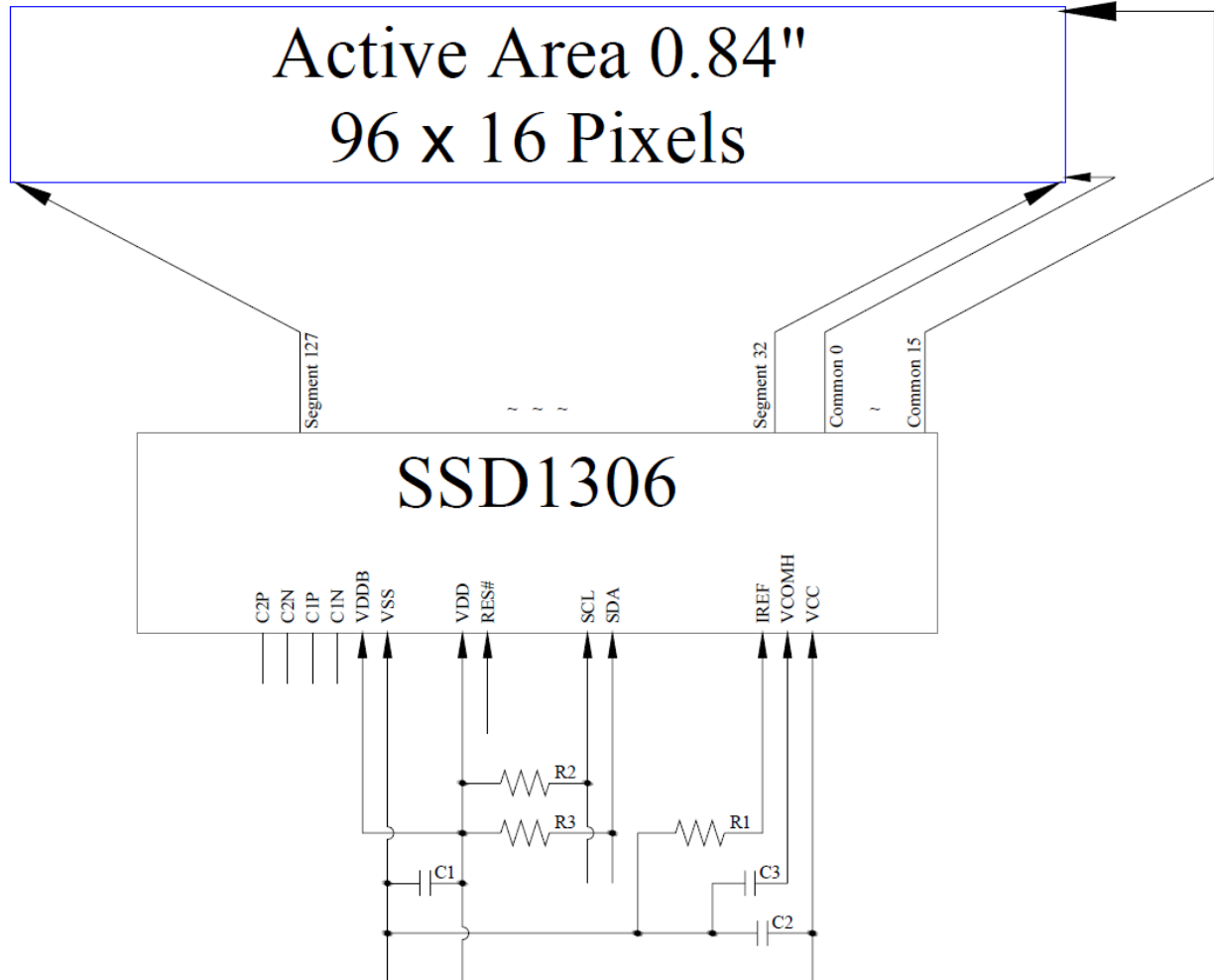

Pins connected to MCU interface: RES#, SCL and SDA

C1: 1uF

C2: 4.7uF

C3: 4.7uF / 16V X7R

R1: 820kΩ, $R1 = (\text{Voltage at IREF} - \text{BGGND}) / \text{IREF}$

R2, R3: 2kΩ

Product No.	DD-9616BE-3A	REV. A

Page	10 / 29
------	---------

3.4.1 Internal DC/DC Circuit

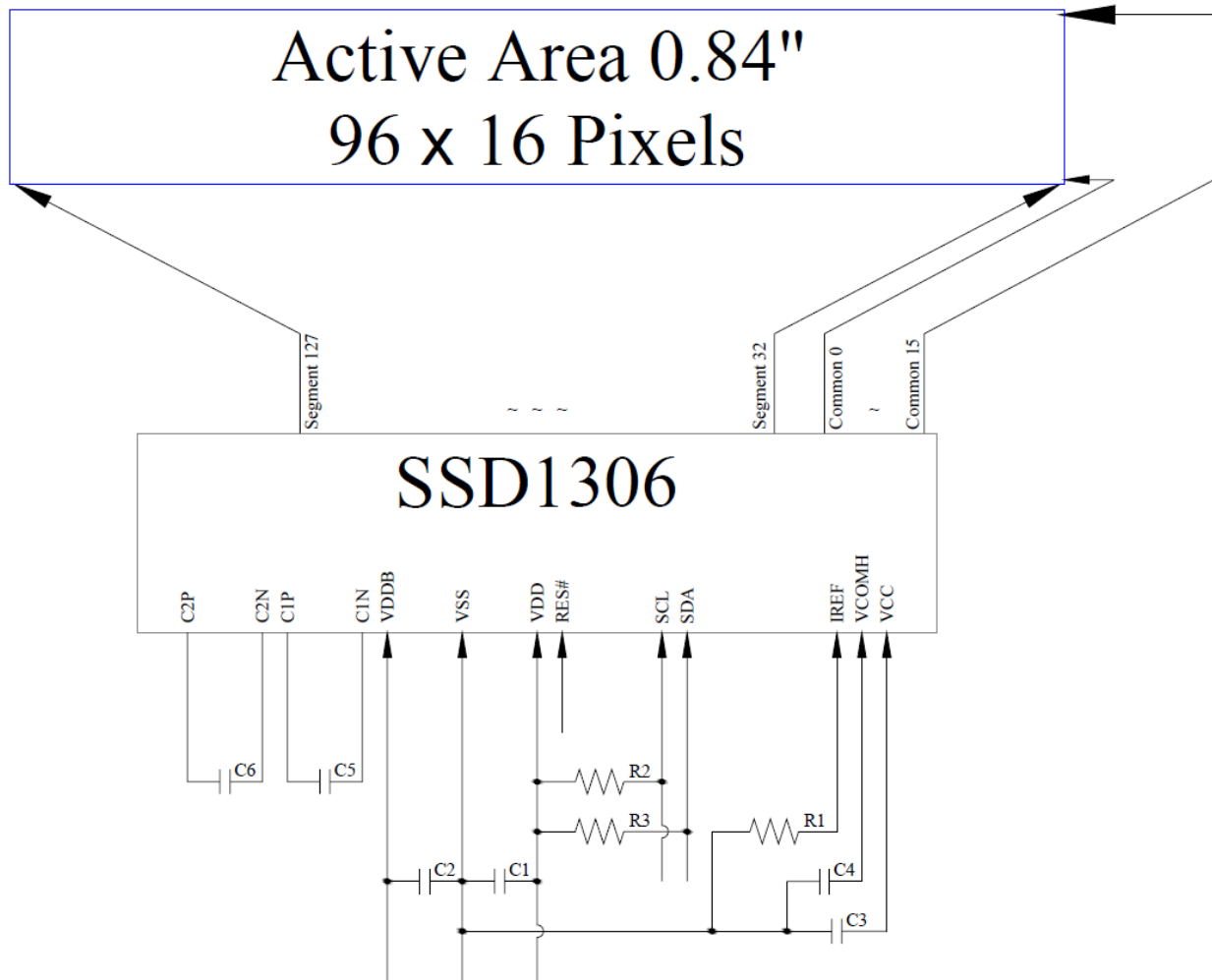

Pins connected to MCU interface: RES#, SCL and SDA

- C1, C2: 1uF
- C3: 2.2uF
- C4: 4.7uF / 16V X7R
- C5, C6: 1uF / 16V X5R
- R1: 820kΩ, $R1 = (\text{Voltage at IREF} - \text{BGGND}) / \text{IREF}$
- R2, R3: 2kΩ

Product No.	DD-9616BE-3A	REV. A

Page	11 / 29
------	---------

AC CHARACTERISTICS

Characteristics	Symbol	Min	Max	Unit
Clock Cycle Time	t_{cycle}	2.5	-	us
Start Condition Hold Time	t_{HSTART}	0.6	-	us
Data Hold Time (for “SDA _{OUT} ” Pin)	t_{HD}	0	-	ns
Data Hold Time (for “SDA _{IN} ” Pin)		300		
Data Setup Time	t_{SD}	100	-	ns
Start Condition Setup Time (Only relevant for a repeated Start condition)	t_{SSTART}	0.6	-	us
Stop Condition Setup Time	t_{SSTOP}	0.6	-	us
Rise Time for Data and Clock Pin	t_{R}	-	300	ns
Fall Time for Data and Clock Pin	t_{F}	-	300	ns
Idle Time before a New Transmission can Start	t_{IDLE}	1.3		us

(VDD – VSS = 2.8V, Ta = 25°C)

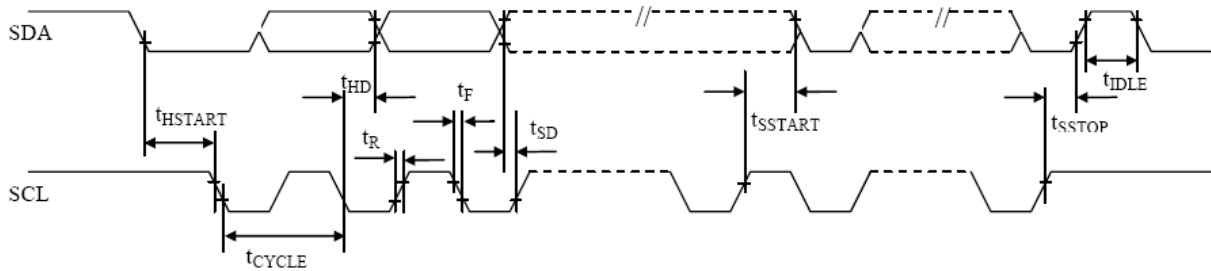

Product No.	DD-9616BE-3A	REV. A

Page	12 / 29
------	---------

4 OPTICAL SPECIFICATION

4.1 OPTICAL CHARACTERISTICS

Characteristics	Symbol	Condition	Min	Typ	Max	Unit
Brightness	L _{br}	With Polarizer	120	150	-	cd/m ²
C.I.E.(White)	(X)	Without Polarizer	0.12	0.16	0.20	-
	(Y)		0.22	0.26	0.30	
Dark Room Contrast	CR		-	>10,000: 1	-	-
Viewing Angle			>160	-	-	degree
Life time				10,000		hour

Optical measurement taken at V_{DD} = 2.8V, V_{CC} = 9V & 7.25V

Software configuration follows Section 5.4 Initialization.

Life time:

V_{CC} = 7.25V, T_a = 25°C, 50% Checkerboard.

Software configuration follows Section 4.4 Initialization.

End of lifetime is specified as 50% of initial brightness reached. The average operating lifetime at room temperature is estimated by the accelerated operation at high temperature conditions.

Product No.	DD-9616BE-3A	REV. A

Page	13 / 29
------	---------

5 FUNCTIONAL SPECIFICATION

5.1 COMMANDS

Please refer to the Technical Manual for the SSD1306

5.2 POWER UP/DOWN SEQUENCE

To protect panel and extend the panel lifetime, the driver IC power up/down routine should include a delay period between high voltage and low voltage power sources during turn on/off. It gives the panel enough time to complete the action of charge and discharge before/after the operation.

5.2.1 POWER UP SEQUENCE

1. Power up V_{DD}/V_{DDB}
2. Send Display off command
3. Initialization
4. Clear Screen
5. Power up V_{CC}
6. Delay 100ms
(When V_{CC} is stable)
7. Send Display on command

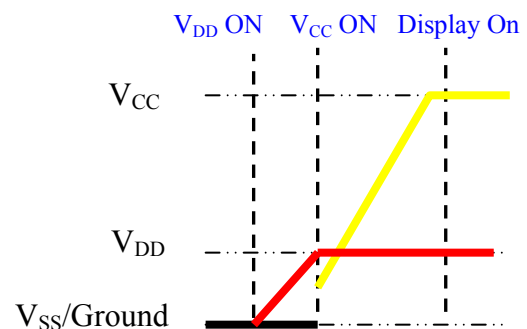

5.2.2 POWER DOWN SEQUENCE

1. Send Display off command
2. Power down V_{CC}/V_{DDB}
3. Delay 100ms
(When V_{CC} is reach 0 and panel is completely discharges)
4. Power down V_{DDIO}

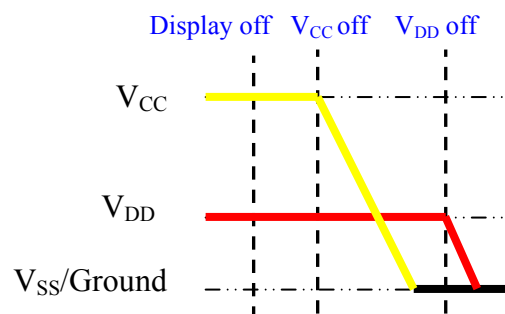

Note:

- 1) Since an ESD protection circuit is connected between V_{DD} and V_{CC} inside the driver IC, V_{CC} becomes lower than V_{DD} whenever V_{DD} is ON and V_{CC} is OFF.
- 2) V_{CC}/V_{DDB} should be kept float (disable) when it is OFF
- 3) Power Pins (V_{DD} , V_{CC} , V_{DDB}) can never be pulled to ground under any circumstance.
- 4) V_{DD} should not be power down before V_{CC}/V_{DDB} power down.

Product No.	DD-9616BE-3A	REV. A

Page	14 / 29
------	---------

5.3 RESET CIRCUIT

When RES# input is low, the chip is initialized with the following status:

1. Display is OFF
2. 128×64 Display Mode
3. Normal segment and display data column and row address mapping (SEG0 mapped to column address 00h and COM0 mapped to row address 00h)
4. Shift register data clear in serial interface
5. Display start line is set at display RAM address 0
6. Column address counter is set at 0
7. Normal scan direction of the COM outputs
8. Contrast control register is set at 7Fh
9. Normal display mode (Equivalent to A4h command)

Product No.	DD-9616BE-3A	REV. A

Page	15 / 29
------	---------

5.4 ACTUAL APPLICATION EXAMPLE

Command usage and explanation of an actual example

5.4.1 External VCC

Power on Sequence

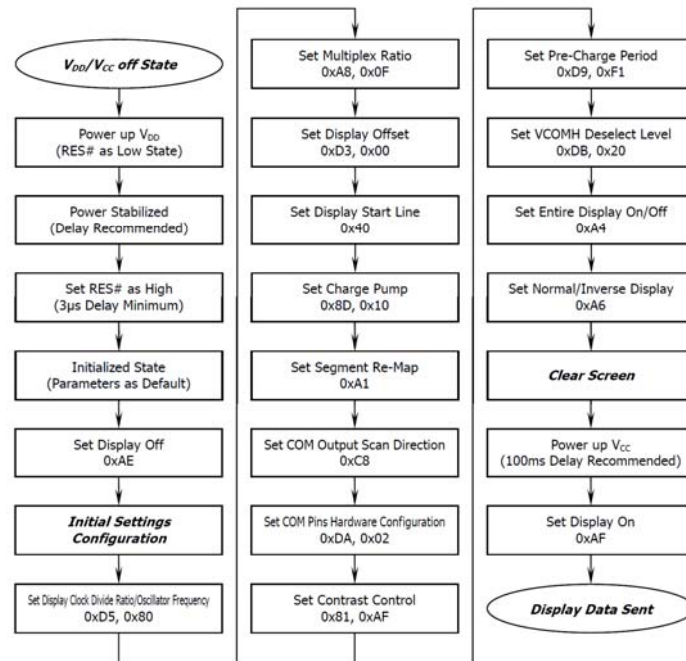

If the noise is accidentally occurred at the displaying window during the operation, please reset the display in order to recover the display function.

Power down Sequence

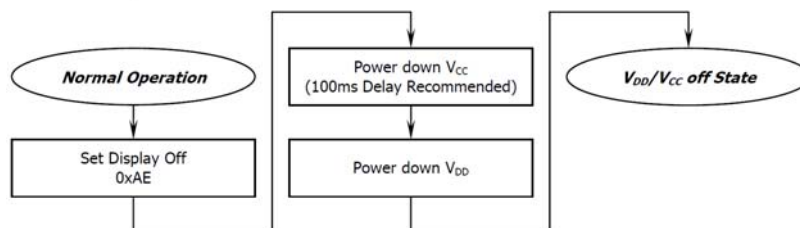

Entering Sleep Mode

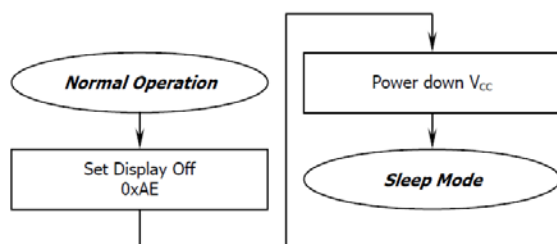

Exiting Sleep Mode

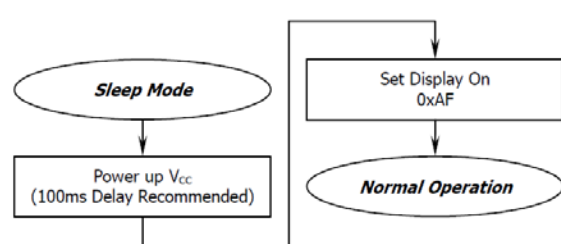

Product No.	DD-9616BE-3A	REV. A
-------------	--------------	--------

Page	16 / 29
------	---------

5.4.2 Internal DC/DC

Power on Sequence

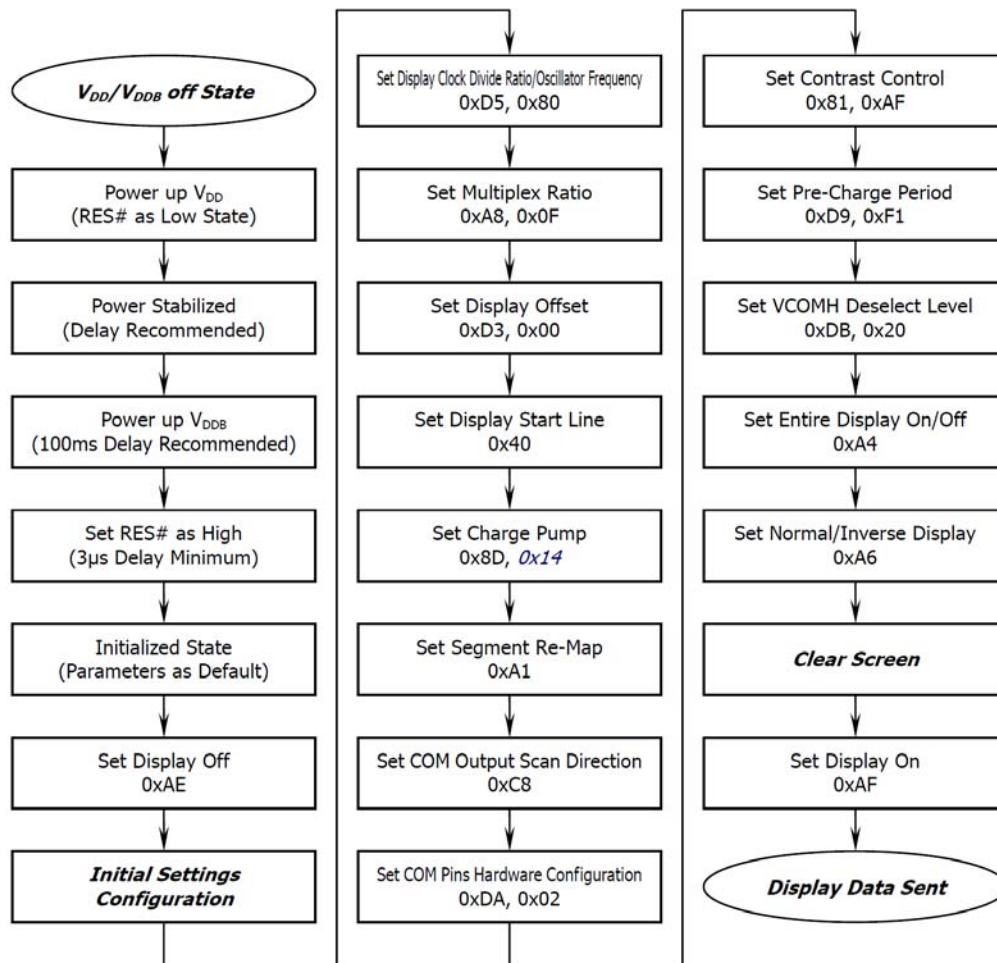

Power down Sequence

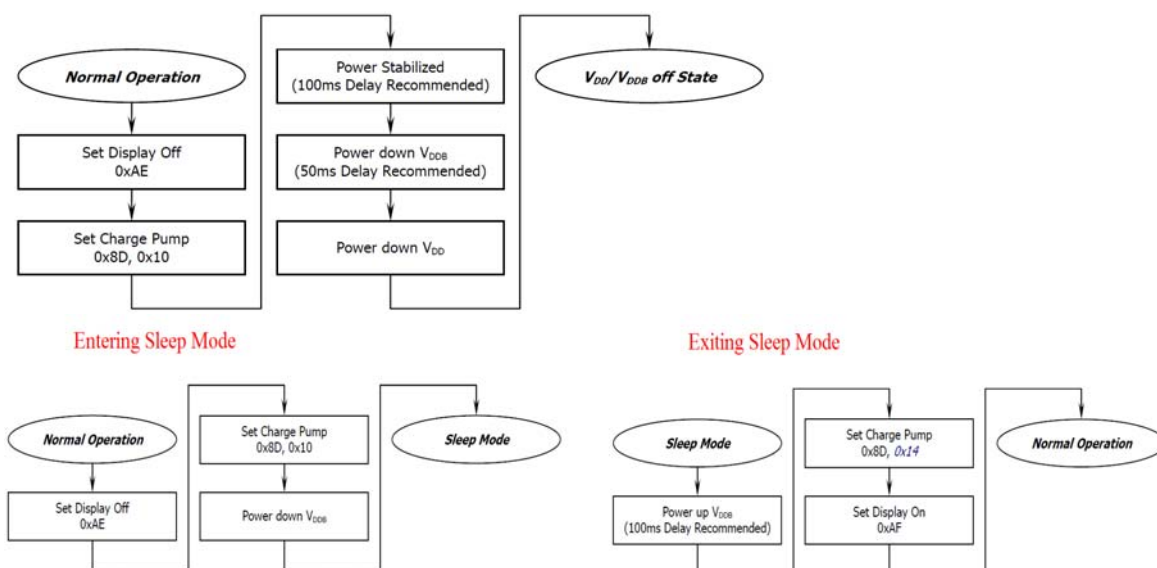

Product No.	DD-9616BE-3A	REV. A

Page	17 / 29
------	---------

6 PACKAGING AND LABELLING SPECIFICATION

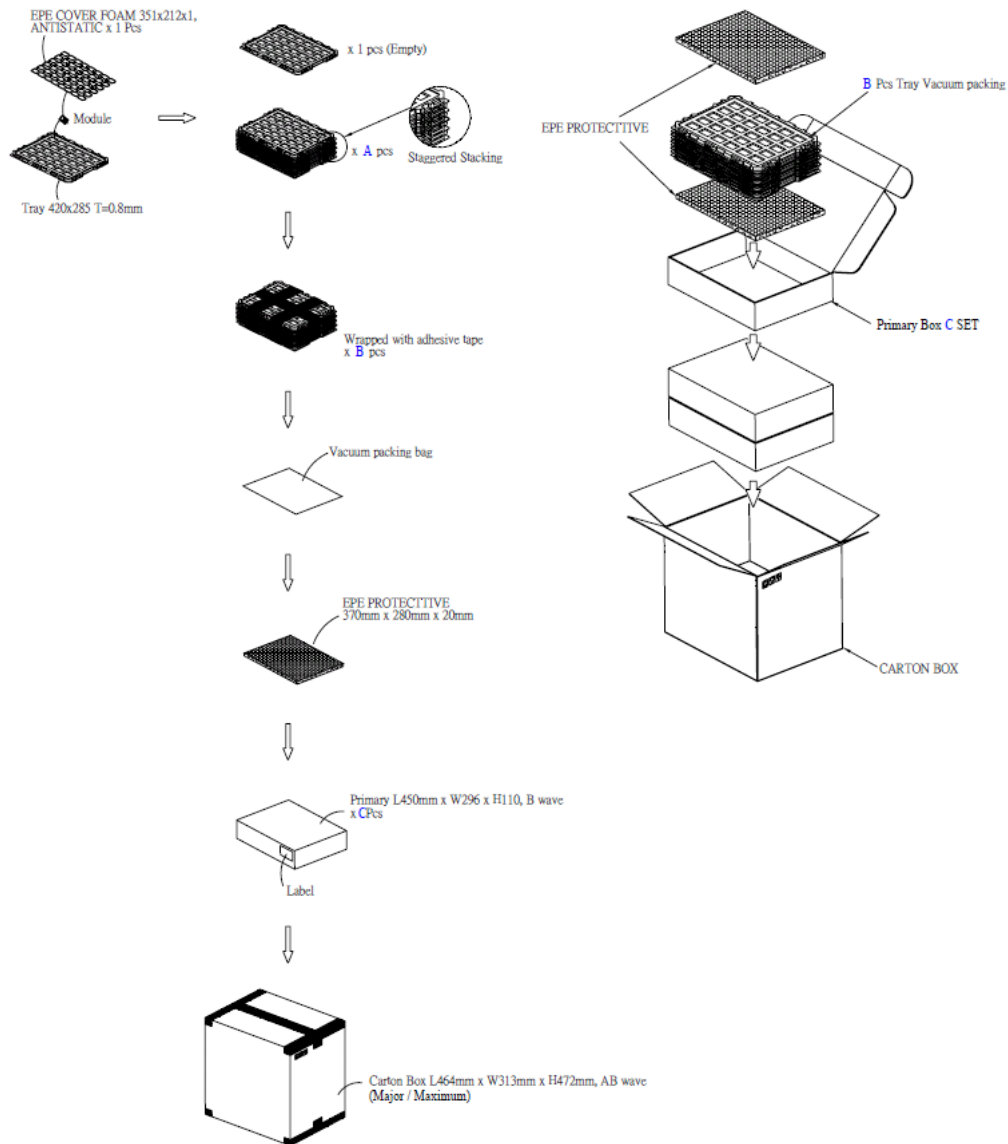

Item	Quantity
Holding Trays (A)	15 per Primary Box
Total Trays (B)	16 per Primary Box (Including 1 Empty Tray)
Primary Box (C)	1~4 per Carton (4 as Major / Maximum)

Product No.	DD-9616BE-3A	REV. A

Page	18 / 29
------	---------

6.1 LABELLING & MARKING

DENSITRON DD-9616BE-3A TW YY MM

7 QUALITY ASSURANCE SPECIFICATION

7.1 CONFORMITY

The performance, function and reliability of the shipped products conform to the Product Specification.

7.2 DELIVERY ASSURANCE

7.2.1 DELIVERY INSPECTION STANDARDS

IPC-AA610, class 2 electronic assembly's standard

7.2.2 Zone definition

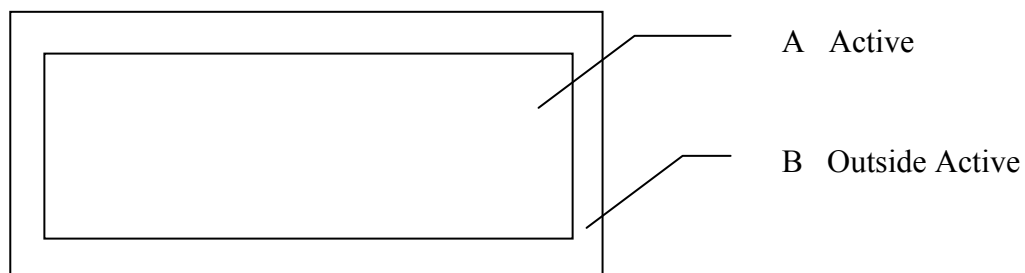

7.2.3 Environment Required

Test and measurement to be conducted under following conditions

Temperature:	23±5°C
Humidity:	55±15%RH
Fluorescent lamp:	30 W
Distance between the Panel & Eyes of the Inspector:	≥30cm
Distance between the Panel & the lamp:	≥50cm



Product No.	DD-9616BE-3A	REV. A

Page	19 / 29
------	---------

7.2.4 Criteria & Acceptable Quality Level

Partition	AQL	Definition
Major	0.65	Defects in Pattern Check (Display On)
Minor	1	Defects in Cosmetic Check (Display Off)

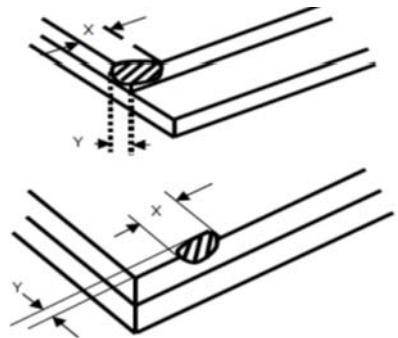
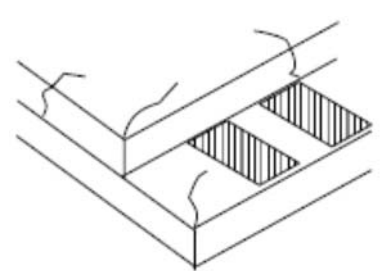
7.2.5 Cosmetic Check (Display Off) in Non Active Area

Check Item	Classification	Criteria
Panel General Chipping	Minor	<p>X > 6 mm (Along with Edge) Y > 1 mm (Perpendicular to edge)</p> 
Panel Crack	Minor	<p>Any crack is not allowable</p> 
Copper Exposed (Even Pin or Film)	Minor	Not Allowable by Naked Eye Inspection
Film or Trace Damage	Minor	

Product No.	DD-9616BE-3A	REV. A

Page	20 / 29
------	---------

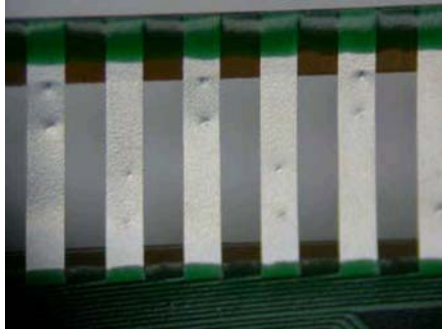
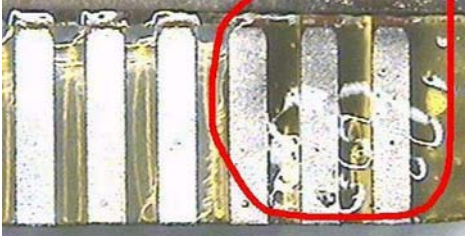
Check Item	Classification	Criteria
Terminal Lead Prober Mark	Acceptable	
Glue or Contamination on Pin (Couldn't Be Removed by Alcohol)	Minor	
Ink Marking on Back Side of panel (Exclude on Film)	Acceptable	Ignore for Any

Product No.	DD-9616BE-3A	REV. A

Page	21 / 29
------	---------

7.2.6 Cosmetic Check (Display Off) in Active Area

It is recommended to execute in clear room environment (class 10k) if actual in necessary

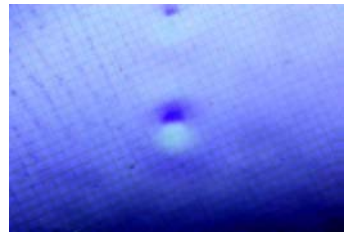
Check Item	Classification	Criteria
Any Dirt & Scratch on Polarizer's Protective Film	Acceptable	Ignore for not Affect the Polarizer
Scratches, Fiber, Line-Shape Defect (On Polarizer)	Minor	$W \leq 0.1$ Ignore $W > 0.1,$ $L \leq 2$ $n \leq 1$ $L > 2$ $n = 0$
Dirt, Black Spot, Foreign Material, (On Polarizer)	Minor	$\Phi \leq 0.1$ Ignore $0.1 < \Phi \leq 0.25$ $n \leq 1$ $0.25 < \Phi$ $n = 0$
Dent, Bubbles, White spot (Any Transparent Spot on Polarizer)	Minor	$\Phi \leq 0.5$ <input type="checkbox"/> Ignore if no Influence on Display $0.5 < \Phi$ $n = 0$ 
Fingerprint, Flow Mark (On Polarizer)	Minor	Not Allowable

Protective film should not be tear off when cosmetic check.

** Definition of W & L & Φ (Unit: mm): $\Phi = (a + b) / 2$

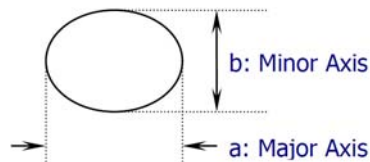
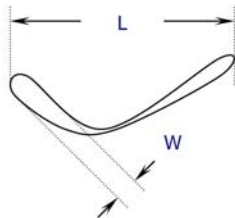

Product No.	DD-9616BE-3A	REV. A

Page	22 / 29
------	---------

7.2.7 Pattern Check (Display On) in Active Area

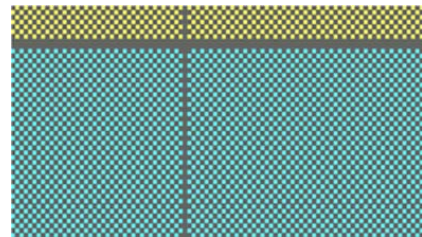
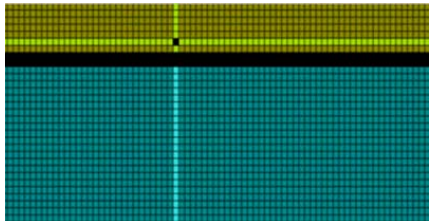
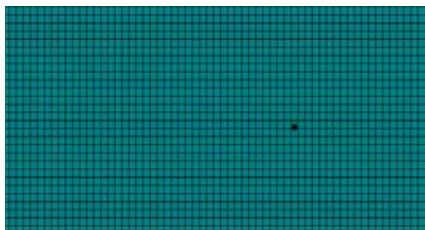
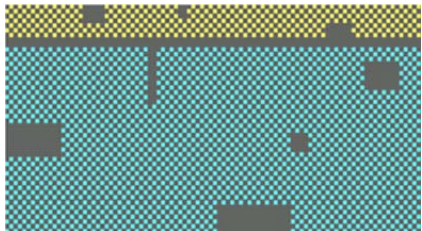
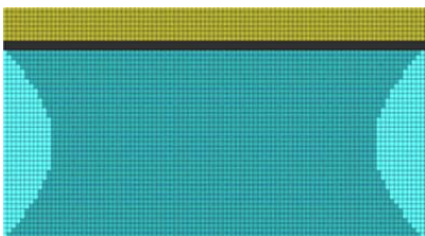
Check Item	Classification	Criteria
No Display	Major	
Missing Line	Major	
Pixel Short	Major	
Darker Pixel	Major	
Wrong Display	Major	
Un-uniform	Major	

Product No.	DD-9616BE-3A	REV. A

Page	23 / 29
------	---------

7.3 DEALING WITH CUSTOMER COMPLAINTS

7.3.1 Non-conforming analysis

Purchaser should supply Densitron with detailed data of non-conforming sample.

After accepting it, Densitron should complete the analysis in two weeks from receiving the sample.

If the analysis cannot be completed on time, Densitron must inform the purchaser.

7.3.2 Handling of non-conforming displays

If any non-conforming displays are found during customer acceptance inspection which Densitron is clearly responsible for, return them to Densitron.

Both Densitron and customer should analyse the reason and discuss the handling of non-conforming displays when the reason is not clear.

Equally, both sides should discuss and come to agreement for issues pertaining to modification of Densitron quality assurance standard.

Product No.	DD-9616BE-3A	REV. A

Page	24 / 29
------	---------

8 RELIABILITY SPECIFICATION

8.1 RELIABILITY TESTS

Test Item	Test Condition	Evaluation and assessment
High Temperature Operation	70°C±2, 240 hours	The operational functions work
Low Temperature Operation	-40°C±2, 240 hours	
High Temperature Storage	85°C±2, 240 hours	
Low Temperature Storage	-40°C±2, 240 hours	
High Temperature & High Humidity Storage(Operation)	60°C±2, 90%RH, 120 hours	
Thermal Shock	-40°C to 85°C, 24 cycles 1 Hour	

- The samples used for above tests do not include polarizer.
- No moisture condensation is observed during tests.

8.1.1 FAILURE CHECK STANDARD

After the completion of the described reliability test, the samples were left at room temperature for 2 hrs prior to conducting the failure test at 23±5 °C;55±15% RH

8.2 LIFE TIME

Item	Description
1	Function, performance, appearance, etc. shall be free from remarkable deterioration more than 10,000 hours under ordinary operating conditions of room temperature (25±10 °C), normal humidity (50% RH), and in area not exposed to direct sunlight.
2	End of lifetime is specified as 50% of initial brightness.

8.3 Failure Check Standard

After the completion of the described reliability test, the samples were left at room temperature for 2 hrs prior to conducting the failure test at 23±5°C; 55±15% RH.

Product No.	DD-9616BE-3A	REV. A
-------------	--------------	--------

Page	25 / 29
------	---------

9 HANDLING PRECAUTIONS

9.1 Handling Precautions

- 1) Since the display panel is being made of glass, do not apply mechanical impacts such as dropping from a high position.
- 2) If the display panel is broken by some accident and the internal organic substance leaks out, be careful not to inhale nor lick the organic substance.
- 3) If pressure is applied to the display surface or its neighborhood of the OEL display module, the cell structure may be damaged and be careful not to apply pressure to these sections.
- 4) The polarizer covering the surface of the OEL display module is soft and easily scratched. Please be careful when handling the OEL display module.
- 5) When the surface of the polarizer of the OEL display module has soil, clean the surface. It takes advantage of by using following adhesion tape.
 - * Scotch Mending Tape No. 810 or an equivalent
 Never try to breathe upon the soiled surface nor wipe the surface using cloth containing solvent such as ethyl alcohol, since the surface of the polarizer will become cloudy.
 Also, pay attention that the following liquid and solvent may spoil the polarizer:
 - * Water
 - * Ketone
 - * Aromatic Solvents
- 6) Hold OEL display module very carefully when placing OEL display module into the system housing. Do not apply excessive stress or pressure to OEL display module. And, do not over bend the film with electrode pattern layouts. These stresses will influence the display performance. Also, secure sufficient rigidity for the outer cases.

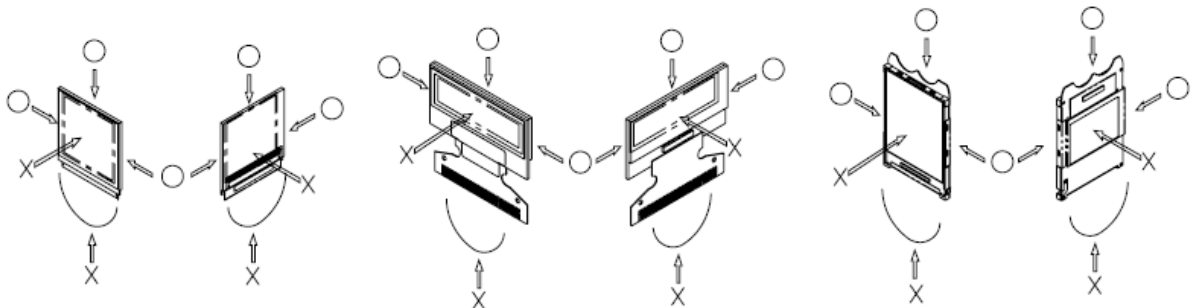

- 7) Do not apply stress to the LSI chips and the surrounding molded sections.
- 8) Do not disassemble nor modify the OEL display module.
- 9) Do not apply input signals while the logic power is off.
- 10) Pay sufficient attention to the working environments when handing OEL display modules to prevent occurrence of element breakage accidents by static electricity.
 - * Be sure to make human body grounding when handling OEL display modules.
 - * Be sure to ground tools to use or assembly such as soldering irons.
 - * To suppress generation of static electricity, avoid carrying out assembly work under dry environments.

Product No.	DD-9616BE-3A	REV. A

Page	26 / 29
------	---------

* Protective film is being applied to the surface of the display panel of the OEL display module. Be careful since static electricity may be generated when exfoliating the protective film.

- 11) Protection film is being applied to the surface of the display panel and removes the protection film before assembling it. At this time, if the OEL display module has been stored for a long period of time, residue adhesive material of the protection film may remain on the surface of the display panel after removed of the film. In such case, remove the residue material by the method introduced in the above Section 5).
- 12) If electric current is applied when the OEL display module is being dewed or when it is placed under high humidity environments, the electrodes may be corroded and be careful to avoid the above.

9.2 Storage Precautions

- 1) When storing OEL display modules, put them in static electricity preventive bags avoiding exposure to direct sun light nor to lights of fluorescent lamps, etc. and, also, avoiding high temperature and high humidity environments or low temperature (less than 0°C) environments. (We recommend you to store these modules in the packaged state when they were shipped from Densitron Technologies Plc.) At that time, be careful not to let water drops adhere to the packages or bags nor let dewing occur with them.
- 2) If electric current is applied when water drops are adhering to the surface of the OEL display module, when the OEL display module is being dewed or when it is placed under high humidity environments, the electrodes may be corroded and be careful about the above.

9.3 Designing Precautions

- 1) The absolute maximum ratings are the ratings which cannot be exceeded for OEL display module, and if these values are exceeded, panel damage may be happen.
- 2) To prevent occurrence of malfunctioning by noise, pay attention to satisfy the VIL and VIH specifications and, at the same time, to make the signal line cable as short as possible.
- 3) We recommend you to install excess current preventive unit (fuses, etc.) to the power circuit (VDD). (Recommend value: 0.5A)
- 4) Pay sufficient attention to avoid occurrence of mutual noise interference with the neighboring devices.
- 5) As for EMI, take necessary measures on the equipment side basically.
- 6) When fastening the OEL display module, fasten the external plastic housing section.
- 7) If power supply to the OEL display module is forcibly shut down by such errors as taking out the main battery while the OEL display panel is in operation, we cannot guarantee the quality of this OEL display module.
- 8) The electric potential to be connected to the rear face of the IC chip should be as follows: US2066
* Connection (contact) to any other potential than the above may lead to rupture of the IC.

Product No.	DD-9616BE-3A	REV. A

Page	27 / 29
------	---------

9.3 Other Precautions

- 1) When an OEL display module is operated for a long of time with fixed pattern may remain as an after image or slight contrast deviation may occur. Nonetheless, if the operation is interrupted and left unused for a while, normal state can be restored. Also, there will be no problem in the reliability of the module.
- 2) To protect OEL display modules from performance drops by static electricity rapture, etc., do not touch the following sections whenever possible while handling the OEL display modules.
 - * Pins and electrodes
 - * Pattern layouts such as the FPC
- 3) With this OEL display module, the OEL driver is being exposed. Generally speaking, semiconductor elements change their characteristics when light is radiated according to the principle of the solar battery. Consequently, if this OEL driver is exposed to light, malfunctioning may occur.
 - * Design the product and installation method so that the OEL driver may be shielded from light in actual usage.
 - * Design the product and installation method so that the OEL driver may be shielded from light during the inspection processes.
- 4) Although this OEL display module stores the operation state data by the commands and the indication data, when excessive external noise, etc. enters into the module, the internal status may be changed. It therefore is necessary to take appropriate measures to suppress noise generation or to protect from influences of noise on the system design.
- 5) We recommend you to construct its software to make periodical refreshment of the operation statuses (re-setting of the commands and re-transference of the display data) to cope with catastrophic noise.

9.4 Precautions when disposing of the OEL display modules

- 1) Request the qualified companies to handle industrial wastes when disposing of the OEL display modules. Or, when burning them, be sure to observe the environmental and hygienic laws and regulations.

Product No.	DD-9616BE-3A	REV. A

Page	28 / 29
------	---------

10 SUPPORTED ACCESSORIES

10.1 DUO KIT

Densitron has developed an easy to use yet powerful development and demonstration tool for driving its range of Active matrix OLED displays from the USB port of a PC.

DUO (Densitron USB OLED) kit is hot pluggable and does not require extra cables or power supply to run, allowing users to be up and running in minutes.

The kit consists of an OLED display with transition Board, USB controller card, mini USB cable and a CD with software application and drivers.

Part number: TBD

10.2 TRANSITION BOARD CARD

A Transition board card is like a daughterboard which is meant to be a circuit board for connections between the baseboards (V-DUO and DUO).

It has connector pins for interfacing between the display and the baseboards.

Part number: TBD

10.3 CONNECTOR BOARD CARD

A Connector board card is also a daughterboard which is a circuit board for connection between a microprocessor or microcontroller (customer's system).

Part number: TBD

10.4 CONNECTORS

Type: Hot bar soldering

Product No.	DD-9616BE-3A	REV. A

Page	29 / 29
------	---------