

< Specifications (Precautions and Prohibitions) >

● **Precaution for circuit design**

- 1) The products are designed and produced for application in ordinary electronic equipment (AV equipment, OA equipment, telecommunication equipment, home appliances, amusement equipment, etc.).
If the products are to be used in devices requiring extremely high reliability (medical equipment, transport equipment, aircraft/spacecraft, nuclear power controllers, fuel controllers, car equipment including car accessories, safety devices, etc.) and whose malfunction or operational error may endanger human life and sufficient fail-safe measures, please consult with the ROHM sales staff in advance. If product malfunctions may result in serious damage, including that to human life, sufficient fail-safe measures must be taken, including the following:
 - [a] Installation of protection circuits or other protective devices to improve system safety
 - [b] Installation of redundant circuits in the case of single-circuit failure

- 2) The products are designed for use in a standard environment and not in any special environments. Application of the products in a special environment can deteriorate product performance. Accordingly, verification and confirmation of product performance, prior to use, is recommended if used under the following conditions:
 - [a] Use in various types of liquid, including water, oils, chemicals, and organic solvents
 - [b] Use outdoors where the products are exposed to direct sunlight, or in dusty places
 - [c] Use in places where the products are exposed to sea winds or corrosive gases, including Cl₂, H₂S, NH₃, SO₂, and NO₂
 - [d] Use in places where the products are exposed to static electricity or electromagnetic waves
 - [e] Use in proximity to heat-producing components, plastic cords, or other flammable items
 - [f] Use involving sealing or coating the products with resin or other coating materials
 - [g] Use involving unclean solder or use of water or water-soluble cleaning agents for cleaning after soldering
 - [h] Use of the products in places subject to dew condensation
 - [i] Use or solder under irradiation of excess infrared rays (IR reflow etc.)

- 3) The products are not radiation resistant.

- 4) The Company is not responsible for any problems resulting from use of the products under conditions not recommended herein.

- 5) The Company should be notified of any product safety issues. Moreover, product safety issues should be periodically monitored by the customer.

- 6) De-rate Power Dissipation (Pd) depending on Ambient temperature (Ta).
When used in sealed area, confirm the actual ambient temperature.

- 7) Confirm that operation temperature is within the specified range described in product specification.

- 8) Failure induced under deviant condition from what defined in the product specification can not be guaranteed.

- 9) When product safety related problems arises, please immediately inform to ROHM, and consider technical counter measure.

- 10) The molding resin of the products is non fire-proof.

UNCONTROLLED

DESIGN	CHECK	APPROVAL	DATE: 2009/10/19	SPECIFICATION No. TSZ13201-RPMS1371-H19-0E
<i>N. Hoshino</i>	<i>Y. Yoshida</i>	<i>J. Dai</i>	REV.: 001	ROHM Co., Ltd.

< Specifications (Precautions and Prohibitions) >

Precaution for Mounting / Circuit board design

- 1) When a highly active halogenous (chlorine, bromine, etc.) flux is used, the remainder of flux may negatively affect product performance and reliability.
- 2) In principle, the reflow soldering method must be used; if flow soldering method is preferred, please consult with the Company in advance.

Regarding Precaution for Mounting / Circuit board design, please specially refer to ROHM Mounting specification.

Precautions Regarding Application Examples and External Circuits

- 1) If change is made to the constant of an external circuit, allow a sufficient margin due to variations of the characteristics of the products and external components, including transient characteristics, as well as static characteristics.
- 2) The application examples, their constants, and other types of information contained herein are applicable only when the products are used in accordance with standard methods. Therefore, if mass production is intended, sufficient consideration to external conditions must be made.

Precaution for Electrostatic

This product is Electrostatic sensitive product, which may be damaged due to Electrostatic discharge. Please take proper caution during manufacturing and storing so that voltage exceeding Product maximum rating won't be applied to products. Please take special care under dry condition (e.g. Grounding of human body / equipment / solder iron, isolation from charged objects, setting of Ionizer, friction prevention and temperature / humidity control).

Precaution for Storage / Transportation

- 1) Product performance and soldered connections may deteriorate if the products are stored in the following places:
 - [a] Where the products are exposed to sea winds or corrosive gases, including Cl₂, H₂S, NH₃, SO₂, and NO₂
 - [b] Where the temperature or humidity exceeds those recommended by the Company
 - [c] Storage in direct sunshine or condensation
 - [d] Storage in high Electrostatic
- 2) Even under ROHM recommended storage condition, solderability of delivery over 1 year old may be degraded.
It is strongly recommended to confirm solderability before using products of which storage time is exceeding recommended storage time period .
However, it gives priority to individual SPEC (technological standard) about recommended keeping condition of each product.
- 3) Store / transport cartons in the correct direction, which is indicated on a carton as a symbol. Otherwise bent leads may occur due to excessive stress applied when dropping of a carton.
- 4) Please use parts of mounting on the side (SMD type) to which the MSL level is provided in the specified time after opening a dry bag. When exceeded the specified time please bake products of individual SPEC the below condition before using.

< Specifications (Precautions and Prohibitions) >

Precaution for product label

QR code printed on ROHM product label is only for internal use, and please do not use at customer site. It might contain a internal part number that is inconsistent with an product part number.

Precaution for disposition

When disposing products please dispose them properly with a industry waste company.

Precaution for Foreign exchange control regulation

- 1) ROHM has not determined whether or not the products are considered “a controlled product or labor ” as specified in the Foreign Exchange and Foreign Trade Control Law. Accordingly, if exportation of the products, either separately or integrated in another company’s products, is intended, or giving the products to persons who are not residents is planed, additional steps are required, based upon the appropriate regulations.

Prohibitions Regarding Industrial Property

- 1) These Specifications contain information related to the ROHM industrial property. Any use of them other than pertaining to theusage of appropriate products is not permitted. Duplication of these Specifications and its disclosure to a third party without the Company’s permission is prohibited.
- 2) Information and data on products, including application examples, contained in these specifications are simply for reference; the Company does not guarantee any industrial property rights, intellectual property rights, or any other rights of a third party regarding this information or data. Accordingly, the Company does not bear any responsibility for:
 - [a] infringement of the intellectual property rights of a third party
 - [b] any problems incurred by the use of the products listed herein.
- 3) The Company prohibits the purchaser of its products to exercise or use the intellectual property rights, industrial property rights, or any other rights that either belong to or are controlled by the Company, other than the right to use, sell, or dispose of the products.

Precautions on Use of Products

- 1) Verification and confirmation of performance characteristics of products, after on-board mounting, is advised.
- 2) In particular, if a transient load (a large amount of load applied in a short period of time, such as pulse) is applied, confirmation of performance characteristics after on-board mounting is strongly recommended. Avoid applying power exceeding normal rated power; exceeding the power rating under steady-state loading condition may negatively affect product performance and reliability.

Other Matters

- 1) Please sign these Specifications and return one copy to the Company.
If a copy is not returned within three months after the issued date specified on the front page of these Specifications, the Company will consider the Specifications accepted.
- 2) If any matter related to these Specifications needs to be clarified, discussions shall be held promptly between the two parties concerned to determine the issue.

1. Device name RPMS1371-H19
2. Construction Semiconductor IC
3. Application Remote control
4. Dimensions fig.4

5. Absolute maximum ratings (Ta=25)

Parameter	Symbol	Spec	Unit	Conditions
Supply Voltage	Vcc	6.3	V	
Output Current	Io	2.0	mA	
Storage Temperature	Tstg	-40 ~ +100		
Operating Temperature	Topr	-40 ~ +85		No dew condensation is allowed

6. Recommended Operating Conditions

Parameter	Symbol	Min	Typ	Max	Unit
Supply Voltage	Vcc	2.7	3.0	3.6	V

7. Electrical, Optical Characteristics (VCC=3V, Ta=25)

Parameter	Symbol	Min	Typ	Max	Unit	Conditions
Consumption Current	Icc	-	300	500	μ A	No outside light, No signal input
Effective Distance	L	5	8	-	m	1 Outer light condition Ee<10(lx)
High Level Output Voltage	VH	2.5	-	-	V	1
Low Level Output Voltage	VL	-	-	0.5	V	1 I sink<200 _μ A
ON Pulse Width	TON	400	600	800	μ s	1 Outer light condition Ee<10(lx)
OFF Pulse Width	TOFF	400	600	800	μ s	1 Outer light condition Ee<10(lx)
Center frequency	f ₀	-	36.7	-	kHz	
Horizontal half angle	1/2	-	34	-	deg	2
Vertical half angle	1/2	-	32	-	deg	2

- 1 The burst wave form mentioned in fig.1 is to be transmitted from standard transmitter (fig.2).
Measure 10th or later pulse width after beginning of transmission.
- 2 The angle which effective distance become 50% of L.(effective distance at =0 °)

8. Measurement Conditions

(1) Transmit signal

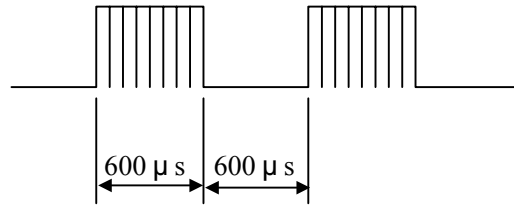

Carrier frequency= f_0 , Duty=50%

fig. 1 Transmit signal

(2) Standard transmitter
peak=940nm
=40nm

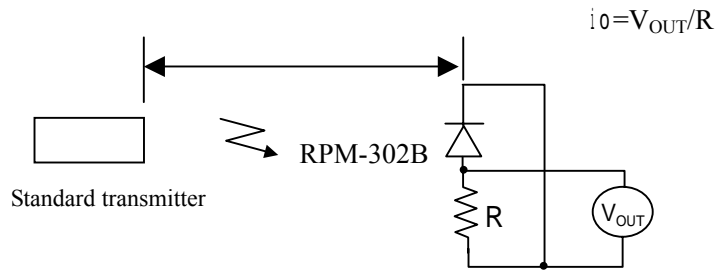

fig.2 Measurement of standard transmitter proof reading

When standard transmitter output the signal at fig.1 standard photodiode output become $i_0 = 5\mu A$ p-p under the measurement condition fig.2.

(The radiant intensity of standard transmitter : 50mW/sr)

RPM-302B: standard photodiode has short current $I_{sc} = 27\mu A$ at $E_e = 1000(lx)$

(Using CIE standard light source A)

(3) Measurement effective distance, horizontal & vertical half angle

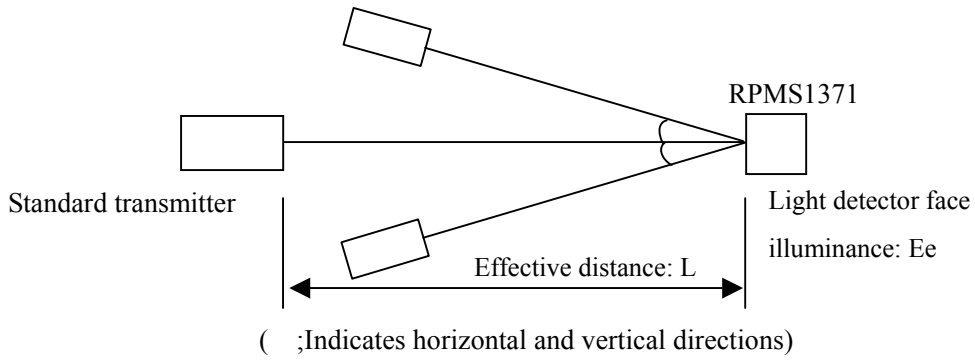
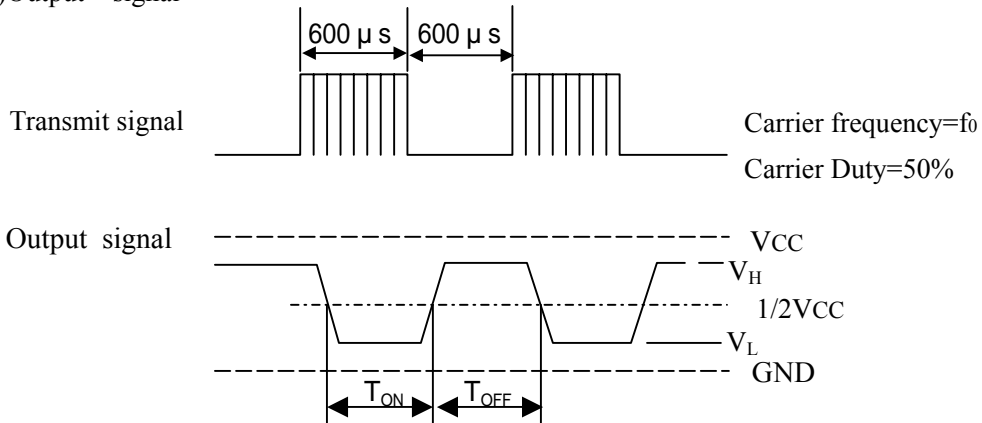

fig.3 Measurement condition for effective distance

Effective distance L : Effective distance at $\theta = 0^\circ$ fig.3
 Horizontal & vertical half angle : The angle which effective distance became 50% of L

(4) Output signal



(5) Measurement circuit for the output voltage and the consumption current

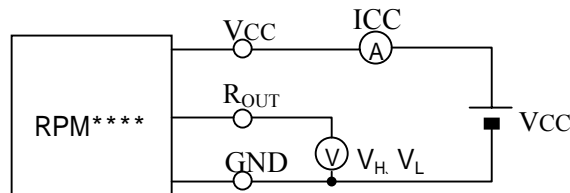

9. Block Diagram

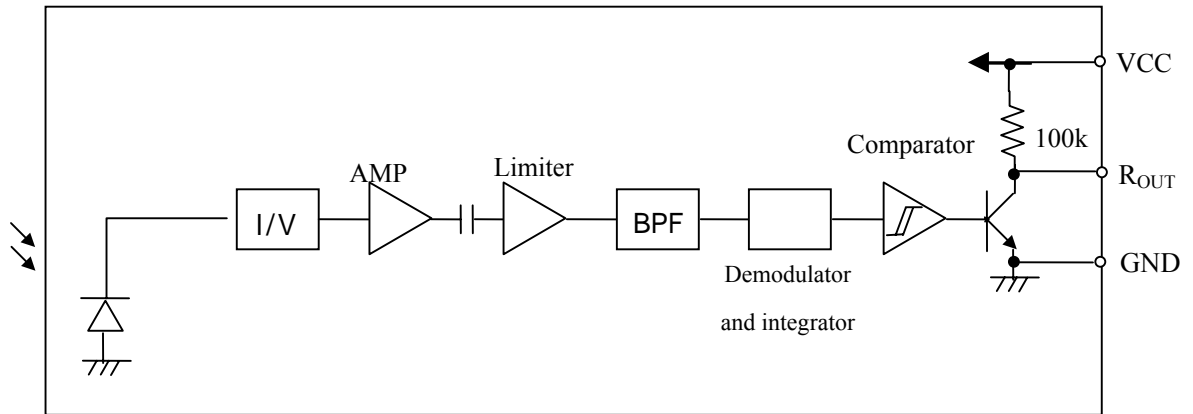

10. Others

This device is not designed as radiation proof.
 There is no laser oscillator in this device.
 There are a photosensitive elements in this device.
 There is no photoconductive circuit in this device.

NOTE

- (1) All characteristics of the receiver in this specification are specified by supplying burst waveform with ROHM standard transmitter (Shown as 8 (2)).
If in case of other burst waveform will be used, please check this specification.
Carefully under the evaluations.
- (2) When the receiver will be used as the wire-less remote controller, please use the signal method the signal format that refers to “Measures to prevent malfunctioning of IR remote-controlled electric home appliances”.
(Published July 1987 by Association of Electric Home Appliances)
If using other signal method, signal format, (ex: signal format which not including the leader signal) the receiver might have chances to miss-function.
- (3) Please set up transmitter’s carrier frequency as same as the receiver’s f0 frequency.
Otherwise error might be occurred.
- (4) If transmission signal has non-continues carrier, error might be occurred.
Continuous carrier is necessary.

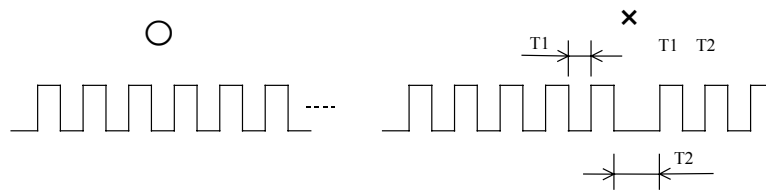

- (5) The receiver was designed to use as in-door use only.
Therefore, please understand that the receiver cannot cover all characteristics, in case of using it out-door.
- (6) Noise environment (Light noise from inverter Lamp, and other kind of Lamps, Power ripple, electromagnetic noise from power circuit, and etc) may cause a reduced effective distance.
- (7) Emitting unit (remote control transmitter) has to be considered about its emitting device function, characteristics and characteristics of the receiver.
- (8) Attach shield case on PCB pattern.
(Shield case does not conduct to GND.)
- (9) Please pay attention to the lens carefully.
It might has a chance to miss-function when the lens get dust or dirty.
Also, please do not touch the lens.
- (10) In order to protect the products from ESD, human body, solder iron, etc are required to be grounded.

fig.4

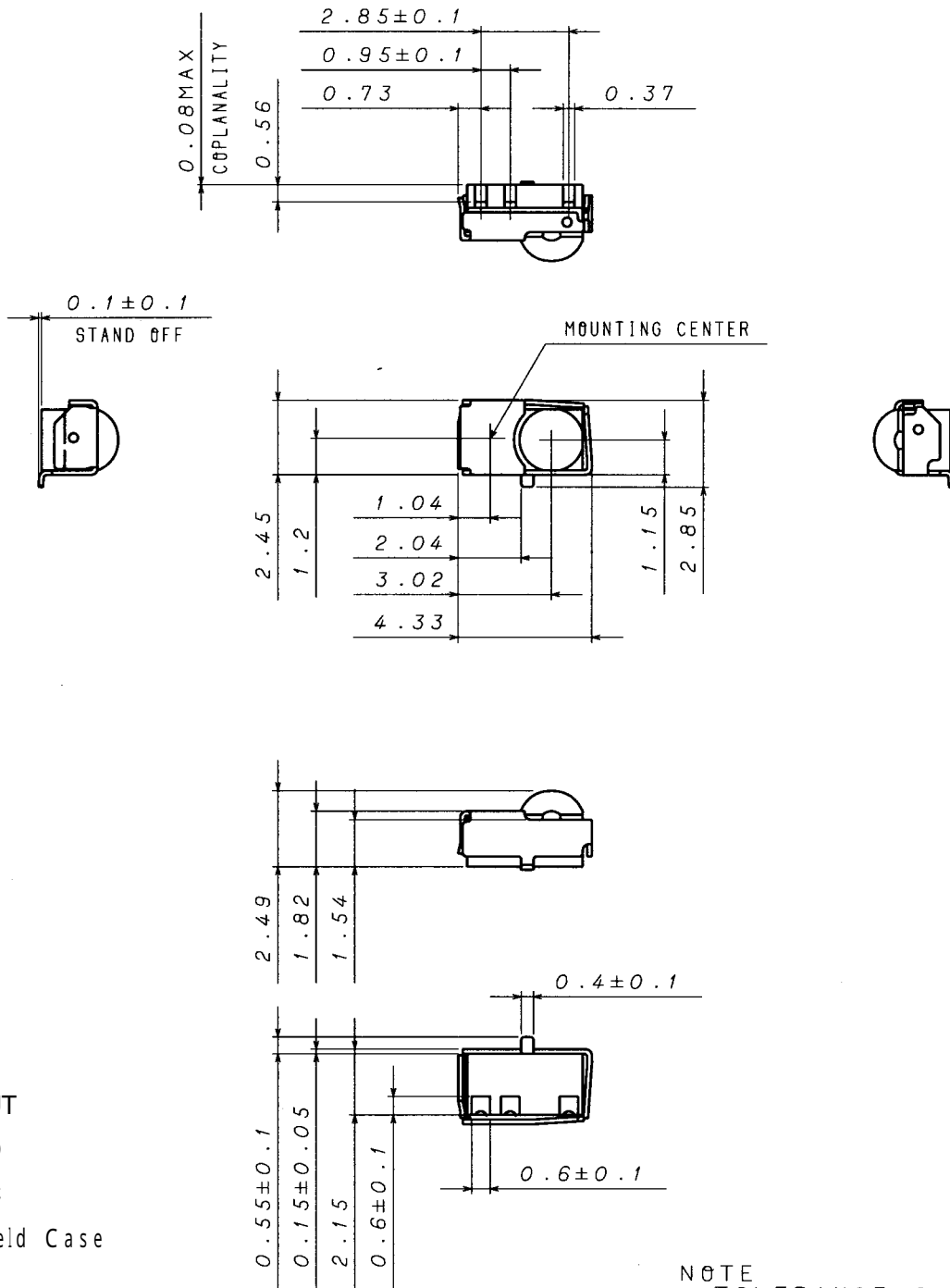

NOTE
TOLERANCE ± 0.2mm
UNIT: mm

Attach shield case on PCB pattern.

実装情報仕様

Information for board assembly

形 状 Package	V R S L P 3 A - H 1 9
----------------	-----------------------

< 目 次 >

< Table of contents >

1. 内部構造図及び材料 Construction & Materials	1/13 Page
2. 包装仕様 Packing specification	2/13 ~ 6/13 Page
3. 半田付け推奨条件 Recommended soldering conditions	7/13 ~ 10/13 Page
4. 標印ロット番号判読法 Meaning of marking lot number	11/13 Page
5. 製造工場 Factory	11/13 Page
6. 信頼性試験項目 Reliability test items	12/13 ~ 13/13 Page

1. 内部構造図及び材料
Construction & Materials

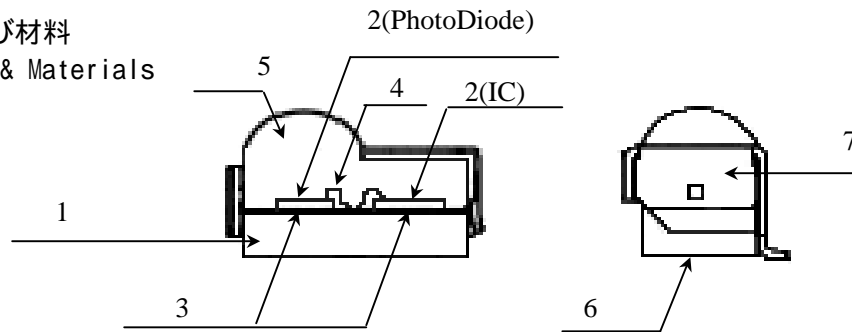

No.	部品名称 Part Name	材料 (製法) Materials (Method)
1.	フレーム Frame	ガラスエポキシ (外部端子 : 金メッキ処理, t=0.3) Glass epoxy (Outer lead : Au plated, t=0.3)
2.	ダイ Die	IC / シリコン フォトダイオード / シリコン IC / Silicone Photo Diode / Silicone
3.	ダイ・アタッチ Die Attach	絶縁ペースト Insulating Paste
4.	ワイヤー Wire	Au線 (超音波併用熱圧着法) Au Wire (Thermosonic wire-bonding)
5.	モールド Molding	非難燃性エポキシ系樹脂 (トランスファーモールド) Non-fireproof Epoxy Resin (Transfer Mold)
6.	標印 Marking	レーザー標印 Laser Marking
7.	シールドケース Shield case	鉄(メッキ材質: Snメッキ 5.5µm, Cu 下地メッキ 0.75µm) Fe(Sn Plated 5.5µm, Cu undercoat plated 0.75 µm)
-	1個当たりの重量 Weight of one Device	0.045 g ± 0.01 g

UNCONTROLLED

DESIGN 	CHECK 	APPROVAL 	DATE: 2009/9/2	SPECIFICATION No.: TSZ13201-VRSLP3A-H19E4A
			REV. 002	ROHM Co., Ltd.

2. 包装仕様

Packing Specification

1) テープ寸法図

Tape Dimension

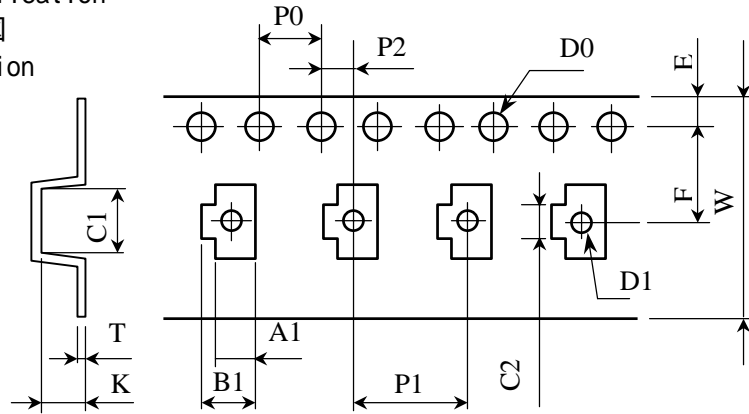

Tape code No.	A1	B1	C1	C2	D0	D1	E	F	P0	P1	P2	T	K	W
-E4/-E4A	2.85	3.45	4.70	1.75	1.5	1.0	1.75	7.5	4.0	8.0	2.0	0.3	2.61	16.0
公差					+0.1									
Tolerance	±0.2	±0.2	±0.2	±0.2	-0	±0.2	±0.1	±0.05	±0.1	±0.01	±0.05	±0.2	±0.2	±0.3

(Unit : mm)

<テープ材質>

ポケット = P S

カバーテープ = P E T

<Tape Material>

Holes

Cover Tape

2) テーピング包装仕様

Packing Specification

2) - 1 製品の整列方向

Arrangements of VRSLP3A Module

製品の裏面がキャリアテープのリール側にあるものを - E 4 または - E 4 A とし (下記参照)
1 リール内は、全て同一方向でテーピングする。

Tape code No. : E4 or E4A ... Every Module 's back face to reel side. (Refer below chart)

All products facing the same within a reel.

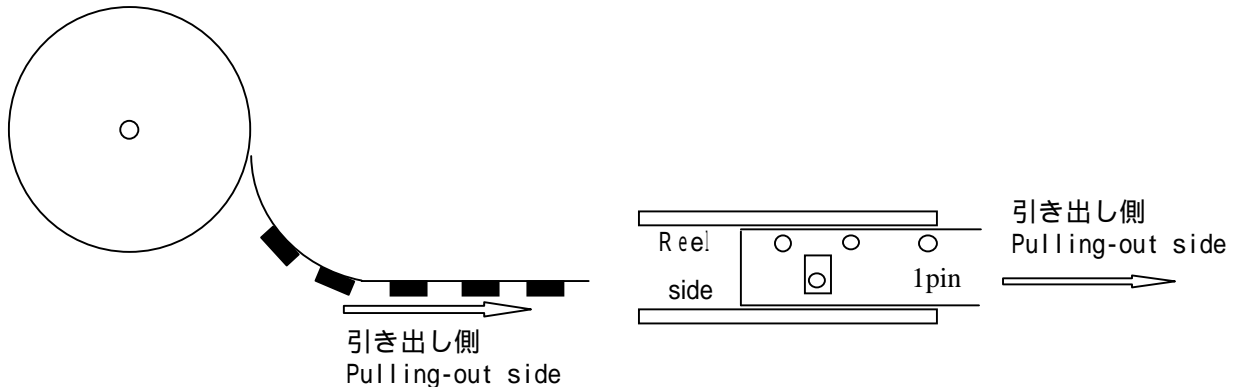

2) - 3 リール梱包方法
Reel Packaging Condition

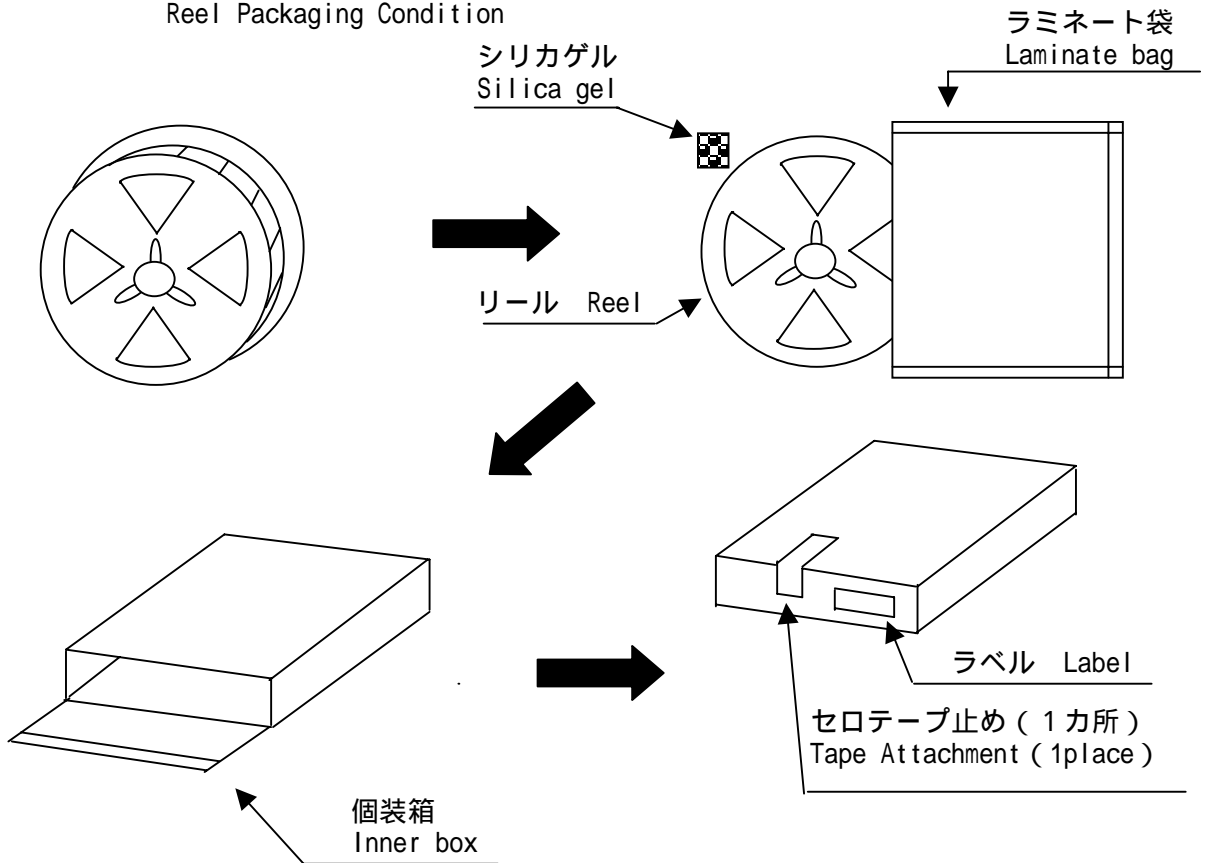

2) - 4 リール寸法
Reel Dimensions

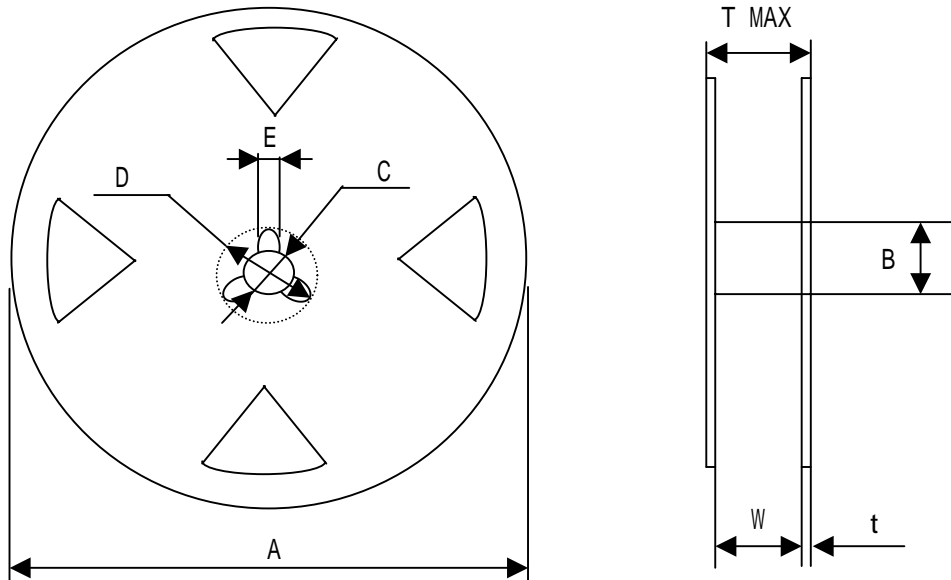

Reel size/ Tape size	A	B	C	D	E	W	t	T MAX
16	330±0.2	100±1	13.0±0.2	21.0±0.8	2.0±0.5	17.5±1	2.0±1	22.4

(Unit: mm)

2) - 5 リーダー及びトレイル部仕様
Leader and Trail of Tape

2) - 5 - 1 リーダー
Leader

リーダー部は、製品が入っていない空部を40ポケット以上設けること。
Leader tape should have over 40 empty pockets.

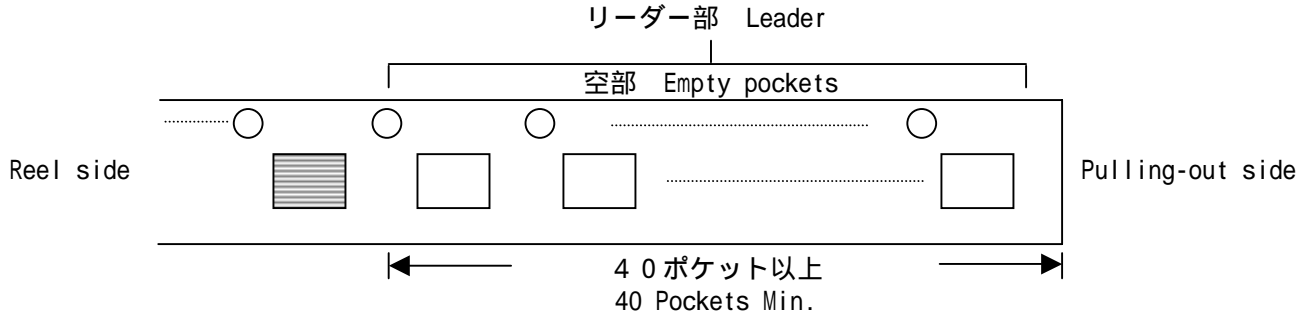

2) - 5 - 2 トレイル
Trail

トレイルテープは、キャリアテープ中に、製品が入っていない部分を10ピッチ以上設けるものとし、リールには直接固定しない。
Trail tape, which has no devices, should have at least 10 pitches.
Trail tape is not fixed to reel.

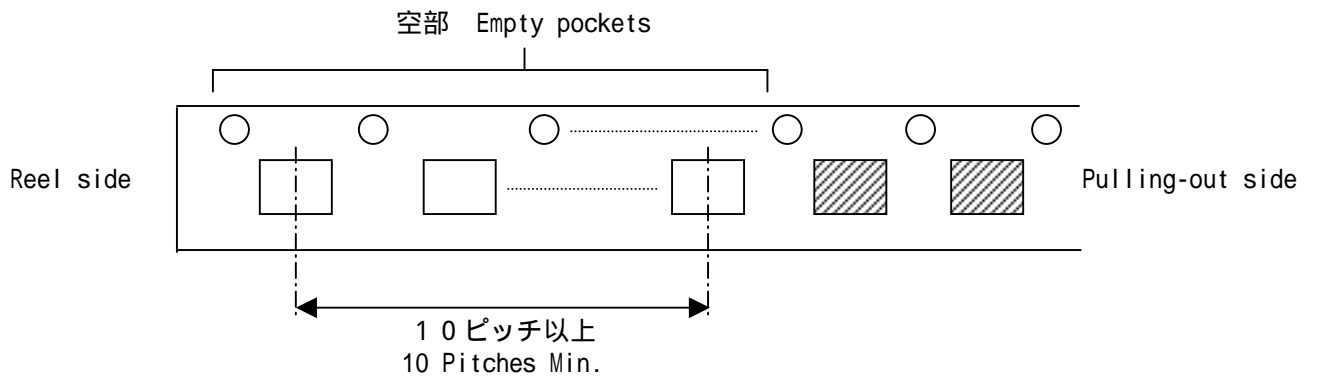

2) - 6 製品封入不良率
Failure Rate at mounting

	発生率 Rate of occurrence	備考 Remarks
連続した抜け Continuous missing	0 %	リーダー部、トレイル部は除く Except leader and trail part
非連続した抜け Uncontinuous missing	MAX 0 . 1 % / 1 reel	

2) - 7 梱包基準数量
Standard packing quantity

Package	Package Quantity	Packing Spec
VRSLP3A-H19	2500 pcs	E4A

- ・ 御発注の際は、基準包装数量の倍数でお願いします。
- ・ 基準包装数に満たない端数の出荷は防湿梱包がされておりませんので、本製品を実装される際には、3 - 5) 項に示します条件にて乾燥処理を実施下さい。
Please order by multiple quantity of standard quantity.
In case of non-multiple quantity, we ship the products without using moisture-proof packing.
So please dry up the products under 3-5) condition before soldering.

2) - 8 発注方法
Ordering

エンボステーピング品御発注には、品名・テーピング方向を次の要領でご指定下さい。

Please indicate Type, Direction of Taping as follows.

(例 ex) RPMS2381-H19 E4A

品名 Type テーピング方向 Direction of Taping

2) - 9

カバーテープの剥離強度は、剥がし速度 300mm/分に於いて、0.2~0.7N(20gf~70gf) とする。

Adhesion strength of cover tape is 0.2~0.7N(20gf~70gf) at peeling speed = 300mm/min.

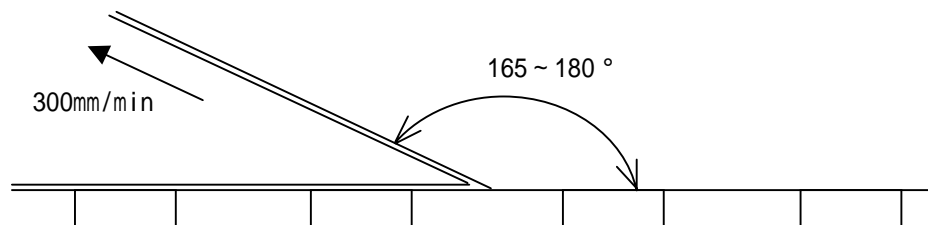

2) - 10 ラベル表示
Label indication

リール・ラミネート袋及び個装箱にラベルを貼付して表示する。
Each reel laminate bag and inner box should have labels, which specifies the followings.

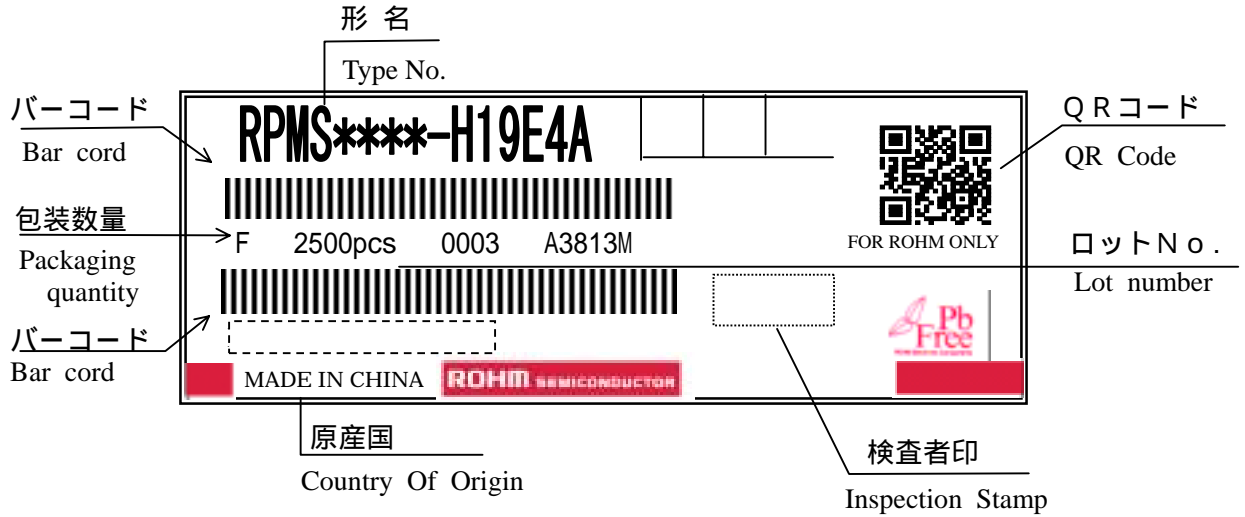

3 . 半田付け推奨条件
Recommended soldering conditions

【推奨実装条件】
【Recommended mounting conditions】

3 - 1) 温風リフロー条件
Hot air reflow condition

パッケージ表面温度 ()
Package surface temperature ()
測定箇所はシールドケース表面の中央部とする。
Measurement point is center of shield case.

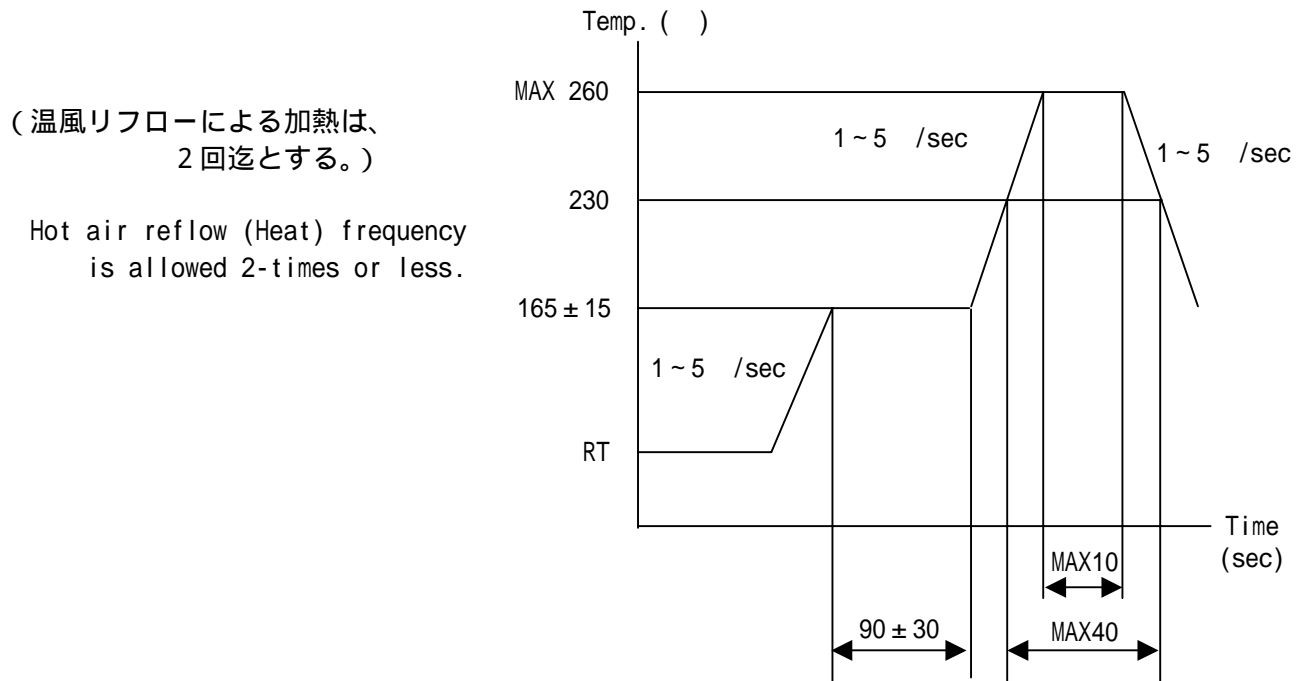

3 - 2) 部分加熱法 (半田ごて使用) の条件
Condition of partial heat method (by soldering iron) is used;

350 MAX 3秒 MAX / pin
350 MAX 3sec MAX / pin

3 - 3) フラックス及び洗浄推奨条件

Recommended Conditions for Flux and Cleaning

3 - 3) - 1 フラックス

Flux

塩素分の少ないロジン系フラックス (塩素分 0.2wt%以下)

Rosin flux with less chlorine. (Chlorine not more than 0.2wt%)

3 - 3) - 2 超音波洗浄条件

Conditions for Ultrasonic cleaning

周波数 : 28KHz

Frequency : 28KHz

超音波出力 : MAX 15W / リットル

Ultrasonic wave output : MAX 15W / liter

溶剤 : アルコール系溶剤を推奨 (当社ではオゾン層保護の取り決めに尊重する立場から。フロン系及び塩素系溶剤による洗浄は推奨しておりません。)

Solvent : Alcoholic solvent is recommended. (From the viewpoint of respecting a decision in protecting the ozone layer, our company does not recommend cleaning with freon or chloride solvents.)

時間 : 30 秒以内 (但し、超音波を使用しない場合は3分以内)

Time : Within 30sec (Within 3min when ultrasonic wave is not used.)

液温 : MAX 40

Solution temperature : MAX 40

< 注意事項 / Cautions >

- ・ デバイスが共振しない事。
- A device must not resonate.
- ・ 振動源にデバイス・プリント基板が直接接触しない事。
- The device print board must not contact directly to the vibration source.
- ・ 洗浄中又は洗浄液がデバイスに付着した状態でブラシや手で標印面をこすらない事。
- Do not rub the marked area of the package with a brush or fingers during cleaning and when the cleaning solvent is adhered to the device.
- ・ 当社ではオゾン層を保護する為の取り決めに尊重する立場より、フロン系及び塩素系溶剤 (1.1.1 - トリクロロエタン) による洗浄を推奨しておりませんが、洗浄についての推奨条件を維持・管理して頂ければ、品質・信頼性を損なうことはないと判断致します。
- From the viewpoint of respecting a decision in protecting the ozone layer, our company does not recommend cleaning with freon or chloride solvents (1.1.1-Trichloroetane), However, Both quality and reliability of the product will not suffer as long as the recommended conditions for cleaning are maintained and controlled.

3 - 4) 表面実装パッケージの実装上の注意事項
Cautions in Mounting the surface Mounting Device

フォトリソクモジュールのパッケージは樹脂でできているため、自然の環境に放置する事により吸湿します。吸湿したパッケージに実装時の熱が加わった場合、特に表面実装パッケージにおいて界面剥離の発生による耐湿性の低下や、パッケージクラックが発生する事がありますので、下記の点に御注意願います。

Since the package of a plastic package is made of resin, it absorbs moisture when exposed in natural environment.

Therefore, when a moist package is heated during mounting, the humidity resistance of the package may deteriorate and / or a package crack may occur particularly on the surface-mounting device.

This is due to the occurrence of an interface peeling.

For this reason, we would like to recommend the following;

製品の保管は、温度 5 ~ 30 °C、相対湿度 50 ± 10 % RH の場所に保管願います。

Please store products in the following conditions;

Temperature : 5 to 30 °C , Humidity : 50 ± 10%RH

防湿梱包を開封から実装まで許容時間は 72 時間と致します。

Allowance time from opening the moisture-proof packing to mounting should be 72 hours.

3 - 5) 乾燥時処理条件
Baking Process

Condition	Temp	Baking time	Total bake time
In reel (tape)	60 ~ 65	48hours	100hours
In bulk	125	24hours	50hours

上記は、防湿梱包開封後、実装までの許容時間を超過した場合、又は、開封前の状態で 12ヶ月以上保管された場合に適用されます。

The above will be applied;

- 1) When the packing is left opened for more than 72 hours.
- 2) When product is kept unused (in unopened packing) over 12 months.

3 - 5) - 1 <テーピング状態での乾燥処理条件>
Baking Condition 's for Taping storage.

- ・ 乾燥温度 : 60 ~ 65
- ・ 乾燥時間 : 48 時間以上
- ・ 乾燥処理の回数は最大 2 回までとし、累積では 100 時間以内として下さい。

< Baking condition of the reel after 72hours opening the moisture proof packing >

- ・ Minimum baking time is 48hours at 60 ~ 65 °C .
- ・ Total baking time must not exceed 100hours total in tape.
- ・ Only bake 2 times maximum.

3 - 5) - 2 <バルク状態での乾燥条件>

Baking Condition 's for Bulk storage.

- 乾燥温度 : 125
- 乾燥時間 : 24 時間以上
- 乾燥処理の回数は最大 2 回までとし、累積では 5 0 時間以内として下さい。

< Baking condition of the reel after 72hours opening the moisture proof packing >

- Minimum baking time is 24hours at 125 .
- Total baking time must not exceed 50hours in total.
- Only bake 2 times maximum.

3 - 6)

本パッケージを半田ディップ法にて実装しますと、実装時のストレスの影響が強く、信頼性に影響を与える可能性がありますので、実装方法としては推奨しかねます。

Solder-dip method mounting is not recommended because it gives extra stress on the device, which will lead to bad influence on its reliability.

4. 標印ロット番号判読法

Meaning of marking lot number

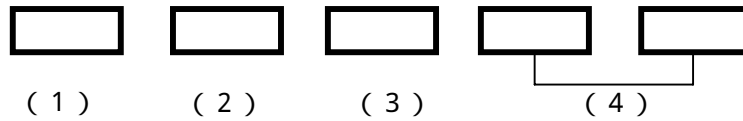

(1) 機種名

Part number

(2) ロットナンバー : 製造年 (西暦) の末尾 1 桁

Lot number : The last digit of production year (the Christian Era)

(3) ロットナンバー : 製造月 1 ~ 9 及び 10 月以降 A. B. C.

Lot number : Production month 1 ~ 9 or October ~ December A. B. C.

(4) 製造ロットナンバー

Production lot number

5. 製造工場

・ローム電子大連有限公司 (中国)

ROHM ELECTRONICS DALIAN CO., LTD. (CHINA)

6. 信頼性試験項目
Reliability test items

1. 耐久性試験 [LTPD10% n=22 C=0 (但し 印の項目は n=5 C=0)]
Quality assurance test [LTPD10% n=22 C=0 (Note ; n=5 C=0)]

No	試験項目 Test item	試験法(条件) Test conditions	規格 Test method															
1	半田付け性 Solder ability	235 ± 5 , 3 ± 0.5 秒 235 ± 5 for 3 ± 0.5sec [面実装タイプは本体を浸漬] [Dipping the body for the surface mounting type] 半田 Sn-3.0Ag-0.5Cu Soldering Sn-3.0Ag-0.5Cu フラックス ロジン 25%含有のメタノール溶剤 methanol solution containing flux rosin 25%	半田浸漬面積の95%以上 半田が付いていること。 Soldering must be made 95% or more of the soldering dip area. [EIAJ-ED-4701-2 試験方法 A131A] [EIAJ-ED-4701-2 Method A131A]															
2	半田耐熱性 Resistance to Soldering heat	【表面実装パッケージ Surface Mount Device】 加湿処理後、温風リフロー加熱(ピーク温度 260) After the moisture soaking treatment, carry out the soldering heat stress(Hot air reflow : Peak260)	個別仕様の電気的特性を満足する事。 Electric properties in independent specification must be satisfied. [EIAJ-ED-4701-2 試験方法 A132] [EIAJ-ED-4701-2 Method A132]															
3	温度サイクル Temperature cycles	下表に示した温度サイクルを繰り返し、100 サイクル行う。 Repeat the temperature cycles for 100 cycles. <table border="1" style="margin-left: 20px;"> <thead> <tr> <th>順序 Order</th> <th>温度() Temperature()</th> <th>時間(分) Time (min)</th> </tr> </thead> <tbody> <tr> <td>1</td> <td>絶対最大定格 Minimum Storage 保存温度 MIN ± 5 Temperature ± 5</td> <td>30</td> </tr> <tr> <td>2</td> <td>5 ~ 35</td> <td>2 ~ 5</td> </tr> <tr> <td>3</td> <td>絶対最大定格 Minimum Storage 保存温度 MAX ± 5 Temperature ± 5</td> <td>30</td> </tr> <tr> <td>4</td> <td>5 ~ 35</td> <td>2 ~ 5</td> </tr> </tbody> </table>	順序 Order	温度() Temperature()	時間(分) Time (min)	1	絶対最大定格 Minimum Storage 保存温度 MIN ± 5 Temperature ± 5	30	2	5 ~ 35	2 ~ 5	3	絶対最大定格 Minimum Storage 保存温度 MAX ± 5 Temperature ± 5	30	4	5 ~ 35	2 ~ 5	個別仕様の電気的特性を満足する事。 Electric properties in independent specification must be satisfied. [EIAJ-ED-4701-3 試験方法 B-131A] [EIAJ-ED-4701-3 Method B-131A]
順序 Order	温度() Temperature()	時間(分) Time (min)																
1	絶対最大定格 Minimum Storage 保存温度 MIN ± 5 Temperature ± 5	30																
2	5 ~ 35	2 ~ 5																
3	絶対最大定格 Minimum Storage 保存温度 MAX ± 5 Temperature ± 5	30																
4	5 ~ 35	2 ~ 5																
4	耐溶剤性 Permanence of marking	温度 23 ± 5 のイソプロピルアルコールに 5 ± 0.5 分浸漬。 Dip in isopropyl alcohol at 23 ± 5 for 5 ± 0.5min	個別仕様の電気的特性を満足する事。 Electric properties in independent specification must be satisfied. 標印が読める事。 Indication must be readable. [EIAJ-ED-4701-3 試験方法 C-121A] [EIAJ-ED-4701-3 Method C-121A]															
5	連続動作 The steady state operating life	最大動作温度 +0/ - 5 にて規定の電源電圧を 1000 時間、連続印加する。 試験終了後 2 時間以上 24 時間以内室温で放置。 Continuously impress specified maximum operation temperature (+0/ - 5) for 1000h. After the test, leave the products in room temperature for more than 2 hours / less than 24 hours.	個別仕様の電気的特性を満足する事。 Electric properties in independent specification must be satisfied. [EIAJ-ED-4701 試験方法 D-101] [EIAJ-ED-4701 Method D-101]															

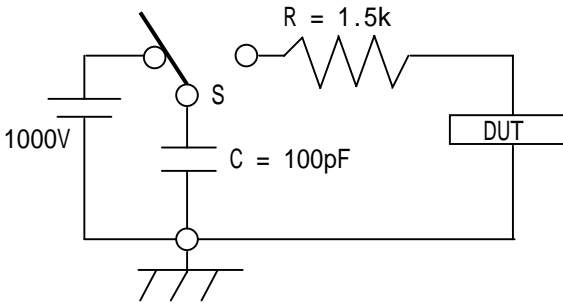
No	試験項目 Test item	試験法 (条件) Test conditions	規格 Test method
6	高温保存 High temperature storage	絶対最大定格保存温度 ± 5 の恒温槽中に 1000 時間放置し、試験終了後 2 時間以上 24 時間以内室温で放置。 Storage at specified maximum storage temperature ± 5 for 1000h. After the test, leave the products in room temperature for more than 2 hours / less than 24 hours.	個別仕様の電気的特性を満足する事。 Electric properties in independent specification must be satisfied. [EIAJ-ED-4701-3 試験方法 B-111A] [EIAJ-ED-4701-3 Method B-111A]
7	低温保存 Low temperature storage	絶対最大定格保存温度 ± 5 の恒温槽中に 1000 時間放置し、試験終了後 2 時間以上 24 時間以内室温で放置。 Storage at specified maximum storage temperature ± 5 for 1000h. After the test, leave the products in room temperature for more than 2 hours / less than 24 hours.	個別仕様の電気的特性を満足する事。 Electric properties in independent specification must be satisfied. [EIAJ-ED-4701-3 試験方法 B-112A] [EIAJ-ED-4701-3 Method B-112A]
8	高温高湿保存 Temperature humidity storage	温度 85 ± 2 、湿度 $85 \pm 5\%RH$ の恒温恒湿槽中に 1000 時間放置し、試験終了後 2 時間以上 24 時間以内室温で放置。 Storage at 85 ± 2 and $85 \pm 5\% RH$ for 1000h. After the test, leave the products in room temperature for more than 2 hours / less than 24 hours.	個別仕様の電気的特性を満足する事。 Electric properties in independent specification must be satisfied. [EIAJ-ED-4701-3 試験方法 B-121A] [EIAJ-ED-4701-3 Method B-121A]
9	高温高湿バイアス Temperature humidity with bias	温度 85 ± 2 、湿度 $85 \pm 5\%RH$ にて、規定の電圧の印加を 1000 時間行う。 Impress specified voltage for 1000h at 85 ± 2 and $85 \pm 5\% RH$. 電圧は断続通電 (1 時間 ON・3 時間 OFF) とする。但し、消費電力が小さい場合は、連続通電を行う。 Voltage is intermittently impressed (1h: ON, 3h: OFF). But when the power consumption is low, the voltage is continuously impressed.	個別仕様の電気的特性を満足する事。 Electric properties in independent specification must be satisfied. [EIAJ-ED-4701-3 試験方法 B-122A] [EIAJ-ED-4701-3 Method B-122A]
10	静電破壊 Electro-Static discharges	コンデンサ (C) に充電し、スイッチ (S) を供試品側にて放電させる。 次に、試験電圧の極性を変えて同じ操作を繰り返す。 Charge to the capacitor (C), and discharge by setting SW (S) to the specimen side, Then, change the polarity of test voltage, and repeat the same operation procedure. 	各端子-GND 間にリークの増加が無い事。 There is no increase of leakage between each pin and GND pin. [EIAJ-ED-4701-1 試験方法 C-111A] [EIAJ-ED-4701-1 Method C-111A]