

ESP32 Hardware Design Guidelines



Espressif Systems

December 2, 2016

About This Guide

ESP32 Hardware Design Guidelines provide technical information on the ESP32 series of products, including ESP32, the ESP-WROOM-32 module, and ESP32-DevKitC - the development board.

Related Resources

For additional documentation and resources on ESP32, please visit the website: [ESP32 Resources](#).

Release Notes

Date	Version	Release notes
2016.12	V1.0	First release.

Disclaimer and Copyright Notice

Information in this document, including URL references, is subject to change without notice. THIS DOCUMENT IS PROVIDED AS IS WITH NO WARRANTIES WHATSOEVER, INCLUDING ANY WARRANTY OF MERCHANTABILITY, NON-INFRINGEMENT, FITNESS FOR ANY PARTICULAR PURPOSE, OR ANY WARRANTY OTHERWISE ARISING OUT OF ANY PROPOSAL, SPECIFICATION OR SAMPLE.

All liability, including liability for infringement of any proprietary rights, relating to use of information in this document is disclaimed. No licenses express or implied, by estoppel or otherwise, to any intellectual property rights are granted herein. The Wi-Fi Alliance Member logo is a trademark of the Wi-Fi Alliance. The Bluetooth logo is a registered trademark of Bluetooth SIG.

All trade names, trademarks and registered trademarks mentioned in this document are property of their respective owners, and are hereby acknowledged.

Copyright © 2016 Espressif Inc. All rights reserved.

Contents

1 Overview	6
1.1 Basic Protocols	6
1.1.1 Wi-Fi	6
1.1.2 Bluetooth	6
1.2 Application	7
1.3 Function Block Diagram	8
2 Pin Definitions	9
2.1 Pin Layout	9
2.2 Pin Description	9
2.3 Strapping Pins	11
3 Schematics and PCB Layout Design	13
3.1 Schematics	13
3.1.1 Power Supply	14
3.1.1.1 Digital Power Supply	14
3.1.1.2 Analog Power Supply	14
3.1.2 Power-on Sequence and Reset	15
3.1.2.1 Power-on Sequence	15
3.1.2.2 Reset	15
3.1.3 Flash	15
3.1.4 Crystal Oscillator	16
3.1.4.1 External Clock Source (compulsory)	16
3.1.4.2 RTC (Optional)	17
3.1.5 RF	17
3.1.6 Sensor External Sampling Capacitor	18
3.1.7 External Capacitor	18
3.2 PCB Layout	18
3.2.1 Standalone ESP32 Module	19
3.2.1.1 General Principles of PCB Layout	19
3.2.1.2 Power Supply	19
3.2.1.3 Crystal Oscillator	19
3.2.1.4 RF	20
3.2.2 ESP32 as a Slave Device	21
3.2.3 Typical Layout Problems and Solutions	21
3.2.3.1 Q: The current ripple is not large, but the Tx performance of RF is rather poor.	21
3.2.3.2 Q: The power ripple is small, but RF Tx performance is poor.	22
3.2.3.3 Q: When ESP32 sends data packages, the power value is much higher or lower than the target power value, and the EVM is relatively poor.	22
3.2.3.4 Q: Tx performance is not bad, but the Rx sensitivity is low.	22
4 Hardware Development	23
4.1 ESP-WROOM-32 Module	23
4.1.1 Overview	23

4.1.2	Pin Definition	24
4.1.3	Notes	25
4.2	ESP32-DevKitC	26
4.2.1	Overview	26
4.2.2	Schematics	27
4.2.2.1	Power Schematics	27
4.2.2.2	USB-UART Schematics	27
5	Applications	28
5.1	UART to Wi-Fi Smart Device	28
5.2	ESP32-Lyra Smart Audio Platform	28

List of Tables

1	Pin Description	9
2	Strapping Pins	12
3	WROOM-32 Pinouts	24
4	Pin Definition of UART Interfaces	28

List of Figures

1	Function Block Diagram	8
2	ESP32 Pin Layout	9
3	ESP32 Schematics	13
4	ESP32 Digital Power Supply Pins	14
5	ESP32 Analog Power Supply Pins	15
6	ESP32 Flash	16
7	ESP32 Crystal Oscillator	16
8	ESP32 Crystal Oscillator (RTC)	17
9	ESP32 RF Schematics	17
10	ESP32 Sensor External Sampling Capacitor	18
11	ESP32 External Capacitor	18
12	ESP32 PCB Layout	19
13	ESP32 Crystal Oscillator	20
14	ESP32 RF	20
15	PAD/TV Box Layout	21
16	ESP-WROOM-32 Module	23
17	ESP-WROOM-32 Pin Layout	23
18	Top view of ESP32-DevKitC	26
19	ESP32-DevKitC Pin Layout	26
20	Power Schematics of ESP32-DevKitC	27
21	USB-UART Schematics	27

1. Overview

ESP32 is a single 2.4 GHz Wi-Fi and Bluetooth combo chip designed with TSMC ultra-low power 40 nm technology. It is designed to achieve the best power performance and RF performance in a wide variety of applications and different power profiles, with robustness, versatility and reliability.

ESP32 is a Wi-Fi plus Bluetooth System-on-a-Chip (SoC). With only 16 external components, it has the optimal level of integration in the industry. It integrates the complete transmit/receive RF functionality including the antenna switches, RF balun, power amplifier, low noise receive amplifier, filters, power management, and advanced calibration circuitries that allow the solution to dynamically adjust itself to external circuit imperfections. As such, the mass production of ESP32 does not require expensive and specialized Wi-Fi testing equipment.

1.1 Basic Protocols

1.1.1 Wi-Fi

- 802.11 b/g/n/e/i
- 802.11 n (2.4 GHz), up to 150 Mbps
- 802.11 e: QoS for wireless multimedia technology
- WMM-PS, UAPSD
- A-MPDU and A-MSDU aggregation
- Block ACK
- Fragmentation and defragmentation
- Automatic Beacon monitoring/scanning
- 802.11 i security features: pre-authentication and TSN
- Wi-Fi Protected Access (WPA)/WPA2/WPA2-Enterprise/Wi-Fi Protected Setup (WPS)
- Infrastructure BSS Station mode/SoftAP mode
- Wi-Fi Direct (P2P), P2P Discovery, P2P Group Owner mode and P2P Power Management
- UMA compliant and certified
- Antenna diversity and selection

1.1.2 Bluetooth

- Compliant with Bluetooth v4.2 BR/EDR and BLE specification
- Class-1, class-2 and class-3 transmitter without external power amplifier
- Enhanced power control
- +10 dBm transmitting power
- NZIF receiver with -98 dBm sensitivity
- Adaptive Frequency Hopping (AFH)
- Standard HCI based on SDIO/SPI/UART

- High-speed UART HCI, up to 4 Mbps
- BT 4.2 controller and host stack
- Service Discover Protocol (SDP)
- General Access Profile (GAP)
- Security Manage Protocol (SMP)
- Bluetooth Low Energy (BLE)
- ATT/GATT
- HID
- All GATT-based profile supported
- SPP-Like GATT-based profile
- BLE Beacon
- A2DP/AVRCP/SPP, HSP/HFP, RFCOMM
- CVSD and SBC for audio codec
- Bluetooth Piconet and Scatternet

1.2 Application

- Generic low-power IoT sensor hub
- Generic low-power IoT loggers
- Video streaming from camera
- Over The Top (OTT) devices
- Music players
 - Internet music players
 - Audio streaming devices
- Wi-Fi-enabled toys
 - Loggers
 - Proximity sensing toys
- Wi-Fi-enabled speech recognition devices
- Audio headsets
- Smart power plugs
- Home automation
- Mesh network
- Industrial wireless control
- Baby monitors
- Wearable electronics

- Wi-Fi location-aware devices
- Security ID tags
- Healthcare
 - Proximity and movement monitoring trigger devices
 - Temperature sensing loggers

1.3 Function Block Diagram

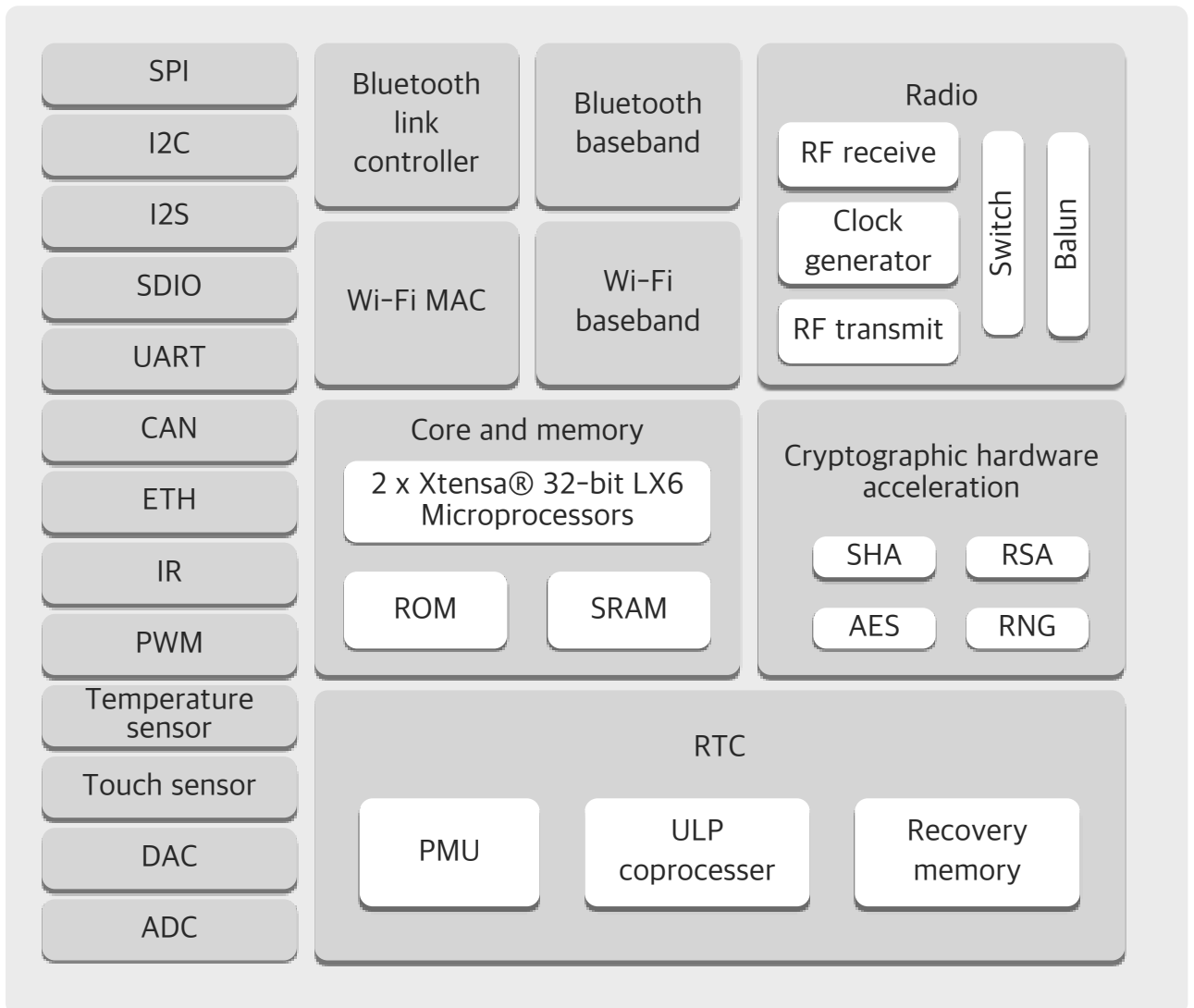

Figure 1: Function Block Diagram

2. Pin Definitions

2.1 Pin Layout

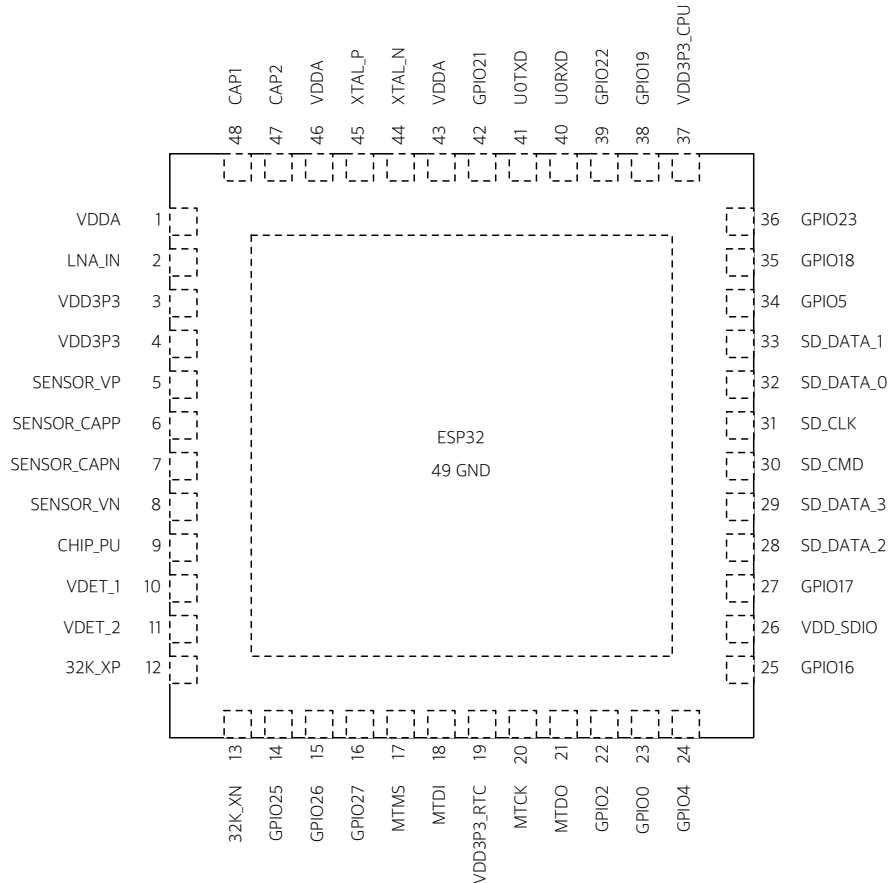

Figure 2: ESP32 Pin Layout

2.2 Pin Description

Table 1: Pin Description

Name	No.	Type	Function
Analog			
VDDA	1	P	Analog power supply (2.3V ~ 3.6V)
LNA_IN	2	I/O	RF input and output
VDD3P3	3	P	Amplifier power supply (2.3V ~ 3.6V)
VDD3P3	4	P	Amplifier power supply (2.3V ~ 3.6V)
VDD3P3_RTC			
SENSOR_VP	5	I	GPIO36, ADC_PRE_AMP, ADC1_CH0, RTC_GPIO0 Note: Connects 270 pF capacitor from SENSOR_VP to SENSOR_CAPP when used as ADC_PRE_AMP.

Name	No.	Type	Function
SENSOR_CAPP	6	I	GPIO37, ADC_PRE_AMP, ADC1_CH1, RTC_GPIO1 Note: Connects 270 pF capacitor from SENSOR_VP to SENSOR_CAPP when used as ADC_PRE_AMP.
SENSOR_CAPN	7	I	GPIO38, ADC1_CH2, ADC_PRE_AMP, RTC_GPIO2 Note: Connects 270 pF capacitor from SENSOR_VN to SENSOR_CAPN when used as ADC_PRE_AMP.
SENSOR_VN	8	I	GPIO39, ADC1_CH3, ADC_PRE_AMP, RTC_GPIO3 Note: Connects 270 pF capacitor from SENSOR_VN to SENSOR_CAPN when used as ADC_PRE_AMP.
CHIP_PU	9	I	Chip Enable (Active High) High: On, chip works properly Low: Off, chip works at the minimum power Note: Do not leave CHIP_PU pin floating
VDET_1	10	I	GPIO34, ADC1_CH6, RTC_GPIO4
VDET_2	11	I	GPIO35, ADC1_CH7, RTC_GPIO5
32K_XP	12	I/O	GPIO32, 32K_XP (32.768 kHz crystal oscillator input), ADC1_CH4, TOUCH9, RTC_GPIO9
32K_XN	13	I/O	GPIO33, 32K_XN (32.768 kHz crystal oscillator output), ADC1_CH5, TOUCH8, RTC_GPIO8
GPIO25	14	I/O	GPIO25, DAC_1, ADC2_CH8, RTC_GPIO6, EMAC_RXD0
GPIO26	15	I/O	GPIO26, DAC_2, ADC2_CH9, RTC_GPIO7, EMAC_RXD1
GPIO27	16	I/O	GPIO27, ADC2_CH7, TOUCH7, RTC_GPIO17, EMAC_RX_DV
MTMS	17	I/O	GPIO14, ADC2_CH6, TOUCH6, RTC_GPIO16, MTMS, HSPI-CLK, HS2_CLK, SD_CLK, EMAC_TXD2
MTDI	18	I/O	GPIO12, ADC2_CH5, TOUCH5, RTC_GPIO15, MTDI, HSPIQ, HS2_DATA2, SD_DATA2, EMAC_TXD3
VDD3P3_RTC	19	P	RTC IO power supply input (1.8V ~ 3.3V)
MTCK	20	I/O	GPIO13, ADC2_CH4, TOUCH4, RTC_GPIO14, MTCK, HSPID, HS2_DATA3, SD_DATA3, EMAC_RX_ER
MTDO	21	I/O	GPIO15, ADC2_CH3, TOUCH3, RTC_GPIO13, MTDO, HSPICS0, HS2_CMD, SD_CMD, EMAC_RXD3
GPIO2	22	I/O	GPIO2, ADC2_CH2, TOUCH2, RTC_GPIO12, HSPIWP, HS2_DATA0, SD_DATA0
GPIO0	23	I/O	GPIO0, ADC2_CH1, TOUCH1, RTC_GPIO11, CLK_OUT1, EMAC_TX_CLK
GPIO4	24	I/O	GPIO4, ADC2_CH0, TOUCH0, RTC_GPIO10, HSPIHD, HS2_DATA1, SD_DATA1, EMAC_TX_ER
VDD_SDIO			
GPIO16	25	I/O	GPIO16, HS1_DATA4, U2RXD, EMAC_CLK_OUT
VDD_SDIO	26	P	1.8V or 3.3V power supply output
GPIO17	27	I/O	GPIO17, HS1_DATA5, U2TXD, EMAC_CLK_OUT_180
SD_DATA_2	28	I/O	GPIO9, SD_DATA2, SPIHD, HS1_DATA2, U1RXD
SD_DATA_3	29	I/O	GPIO10, SD_DATA3, SPIWP, HS1_DATA3, U1TXD
SD_CMD	30	I/O	GPIO11, SD_CMD, SPICS0, HS1_CMD, U1RTS
SD_CLK	31	I/O	GPIO6, SD_CLK, SPICLK, HS1_CLK, U1CTS

Name	No.	Type	Function
SD_DATA_0	32	I/O	GPIO7, SD_DATA0, SPIQ, HS1_DATA0, U2RTS
SD_DATA_1	33	I/O	GPIO8, SD_DATA1, SPID, HS1_DATA1, U2CTS
VDD3P3_CPU			
GPIO5	34	I/O	GPIO5, VSPICS0, HS1_DATA6, EMAC_RX_CLK
GPIO18	35	I/O	GPIO18, VSPICLK, HS1_DATA7
GPIO23	36	I/O	GPIO23, VSPID, HS1_STROBE
VDD3P3_CPU	37	P	CPU IO power supply input (1.8V ~ 3.3V)
GPIO19	38	I/O	GPIO19, VSPIQ, U0CTS, EMAC_TXD0
GPIO22	39	I/O	GPIO22, VSPIWP, U0RTS, EMAC_TXD1
U0RXD	40	I/O	GPIO3, U0RXD, CLK_OUT2
U0TXD	41	I/O	GPIO1, U0TXD, CLK_OUT3, EMAC_RXD2
GPIO21	42	I/O	GPIO21, VSPIHD, EMAC_TX_EN
Analog			
VDDA	43	I/O	Analog power supply (2.3V - 3.6V)
XTAL_N	44	O	External crystal output
XTAL_P	45	I	External crystal input
VDDA	46	P	Power supply for PLL (2.3V ~ 3.6V)
CAP2	47	I	Connects with a 3 nF capacitor and 20 k Ω resistor in parallel to CAP1
CAP1	48	I	Connects with a 10 nF series capacitor to ground
GND			
GND	49	P	GND

Notice:

GPIO36, GPIO37, GPIO38, GPIO39, GPIO34 and GPIO35 can only be used for input.

2.3 Strapping Pins

ESP32 has six strapping pins:

- MTDI/GPIO12: internal pull-down
- GPIO0: internal pull-up
- GPIO2: internal pull-down
- GPIO4: internal pull-down
- MTDO/GPIO15: internal pull-up
- GPIO5: internal pull-up

Software can read the value of these six bits from the register "GPIO_STRAPPING".

During the chip power-on reset, the latches of the strapping pins sample the voltage level as strapping bits of "0" or "1", and hold these bits until the chip is powered down or shut down. The strapping bits configure the device boot mode, the operating voltage of VDD_SDIO and other system initial settings.

Each strapping pin is connected with its internal pull-up/pull-down during the chip reset. Consequently, if a strapping pin is unconnected or the connected external circuit is high-impedance, the internal weak pull-up/pull-down will determine the default input level of the strapping pins.

To change the strapping bit values, users can apply the external pull-down/pull-up resistances, or apply the host MCU's GPIOs to control the voltage level of these pins when powering on ESP32.

After reset, the strapping pins work as the normal function pins.

Please see Table 2 for detailed boot modes configuration by strapping pins.

Table 2: Strapping Pins

Voltage of Internal LDO (VDD_SDIO)					
Pin	Default	3.3V		1.8V	
MTDI	Pull-down	0		1	
Bootling Mode					
Pin	Default	SPI Boot		Download Boot	
GPIO0	Pull-up	1		0	
GPIO2	Pull-down	Don't-care		0	
Debugging Log on U0TXD During Bootling					
Pin	Default	U0TXD Toggling		U0TXD Silent	
MTDO	Pull-up	1		0	
Timing of SDIO Slave					
Pin	Default	Falling-edge Input Falling-edge Output	Falling-edge Input Rising-edge Output	Rising-edge Input Falling-edge Output	Rising-edge Input Rising-edge Output
MTDO	Pull-up	0	0	1	1
GPIO5	Pull-up	0	1	0	1

Note:

Firmware can configure register bits to change the setting of "Voltage of Internal LDO (VDD_SDIO)" and "Timing of SDIO Slave" after bootling.

A detailed description of these aspects follows.

3.1.1 Power Supply

3.1.1.1 Digital Power Supply

Pin19 and Pin37 are the power supply pins for RTC and CPU, respectively. The digital power supply operates in a voltage range of 1.8V ~ 3.3V. We recommend adding extra filter capacitors close to the digital power supply pins.

The internal LDO of VDD_SDIO can be the 1.8V or 3.3V power supply for the external circuit, with a maximum current of about 40 mA. The user can add a 1μF filter capacitor close to VDD_SDIO. When VDD_SDIO connects to VDD3P3_RTC, the LDO will be disabled.

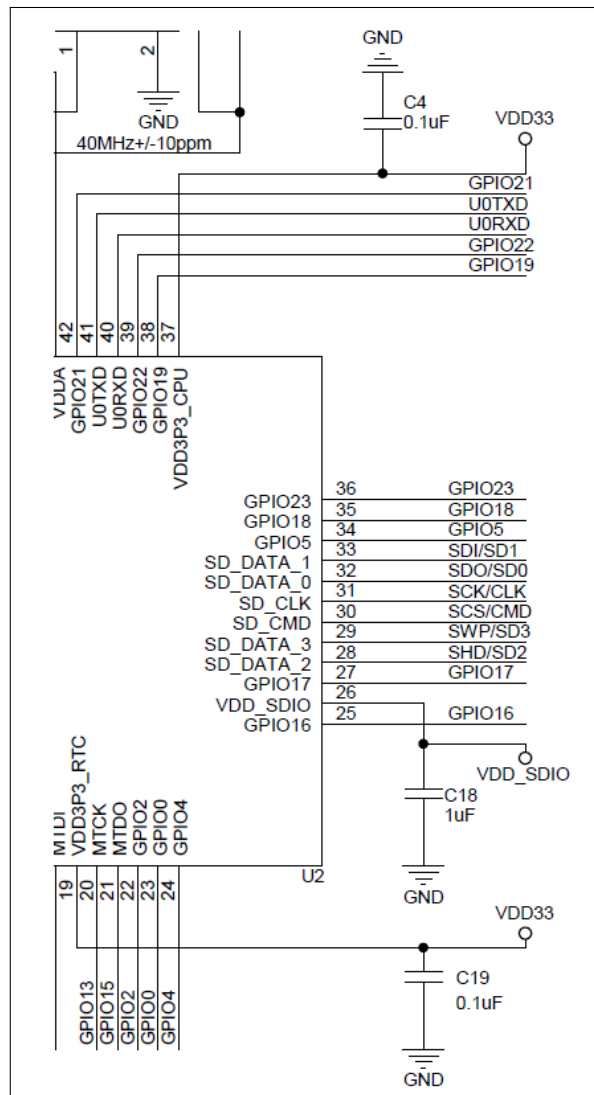

Figure 4: ESP32 Digital Power Supply Pins

3.1.1.2 Analog Power Supply

Pin1, Pin43 and Pin46 are the analog power supply pins. Pin3 and Pin4 are the power supply pins for the power amplifiers. It should be noted that the sudden increase of current, when ESP32 is in transmitting mode, may cause

a power rail collapse. Therefore, it is recommended to add another 0603 10 μF capacitor to the power trace, which can work in conjunction with the 0402 0.1 μF capacitor.

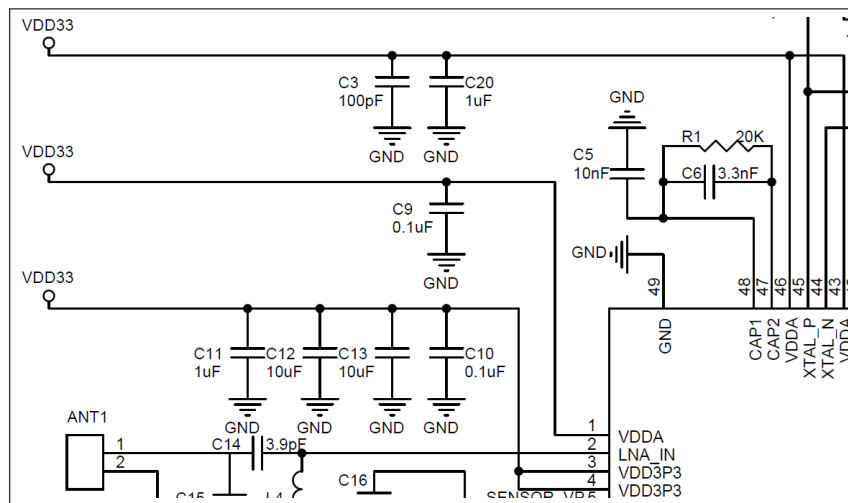

Figure 5: ESP32 Analog Power Supply Pins

3.1.2 Power-on Sequence and Reset

3.1.2.1 Power-on Sequence

ESP32 uses a 3.3V system power supply. There is only one guideline that should be followed with regard to the power-on sequence: The Pin9 CHIP_PU should be powered on later than, or at the same time as, the 3.3V system power supply pin.

Notice:

If CHIP_PU is connected to the power management chip, then the power management chip controls ESP32's power state. When the power management chip turns on/off Wi-Fi through the high/low level on GPIO, a pulse current may be generated. To avoid level instability on CHIP_PU, an RC delay ($R=1\text{ k}\Omega$, $C=100\text{ nF}$) is needed.

3.1.2.2 Reset

CHIP_PU serves as the reset pin of ESP32. ESP32 will power off when CHIP_PU is held low. To avoid reboots caused by external interferences, the CHIP_PU trace should be as short as possible, while a pull-up resistor and a ground capacitor are recommended.

Notice:

CHIP_PU pin cannot be floating.

3.1.3 Flash

ESP32 can support up to four 16 MB external QSPI flash and SRAM. The demo flash used currently is an SPI flash with 4 MB ROM, in an SOIC_8 (SOP_8) package. The VDD_SDIO acts as the power supply pin. Make sure you

select the appropriate flash according to the power voltage on VDD_SDIO. Users can add a 0402 serial resistor to Pin21 SD_CLK and connect it to the Flash CLK pin. The resistor can reduce driving current, eliminate crosstalk and external interference, and adjust sequence.

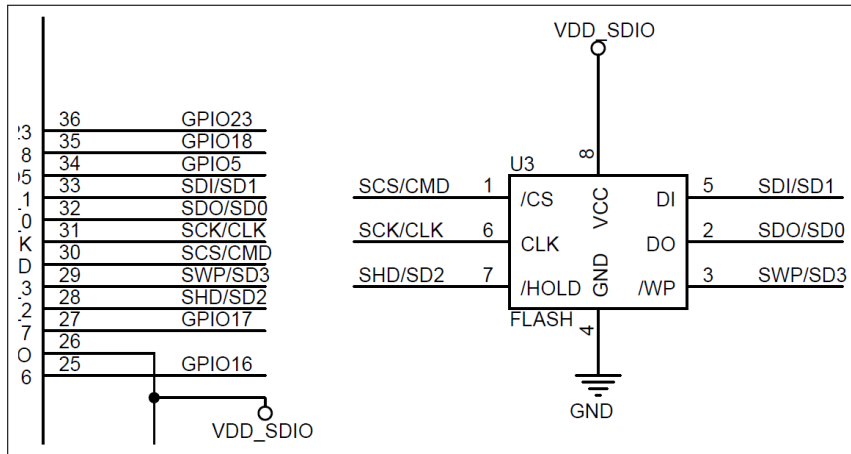

Figure 6: ESP32 Flash

3.1.4 Crystal Oscillator

There are two clock sources for ESP32, that is, an external crystal oscillator clock source and an RTC clock source.

3.1.4.1 External Clock Source (compulsory)

ESP32 can support 40 MHz, 26 MHz, and 24 MHz crystal oscillators. When using ESP32, please make sure you select the right crystal oscillator frequency in the flash download tool. In circuit design, capacitors C1 and C2 are added to the input and output terminals of the crystal oscillator, respectively. The values of the two capacitors can be flexible, ranging from 6 pF to 22 pF. However, the specific capacitive values depend on further testing of, and adjustment to, the overall performance of the whole circuit. Normally, the capacitive values of C1 and C2 are within 10 pF for the 26 MHz crystal oscillator. For 40 MHz crystal oscillator, $C1 \geq 10pF$, $C2 \leq 22pF$. The accuracy of the crystal oscillator should be ± 10 PPM. The operating temperature range should be from $-20^{\circ}C$ to $85^{\circ}C$.

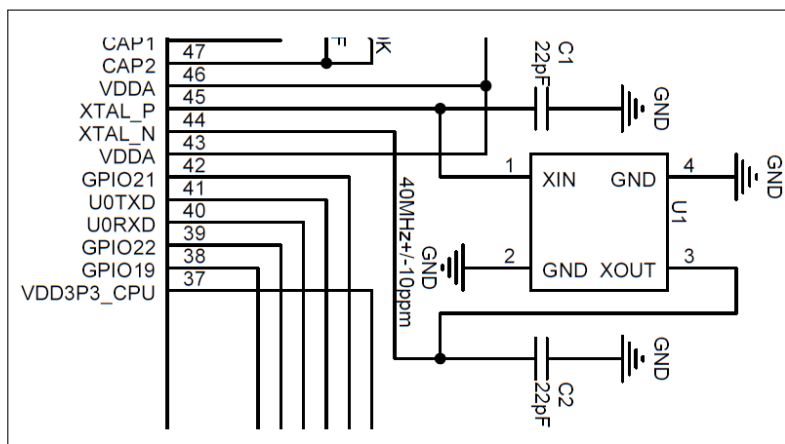

Figure 7: ESP32 Crystal Oscillator

Notice:

Defects in the craftsmanship of the crystal oscillators (for example, high frequency deviation) and unstable working temperature may lead to the malfunction of ESP32, resulting in the decrease of the overall performance.

3.1.4.2 RTC (Optional)

ESP32 supports the external 32 kHz crystal oscillator to act as the RTC sleep clock.

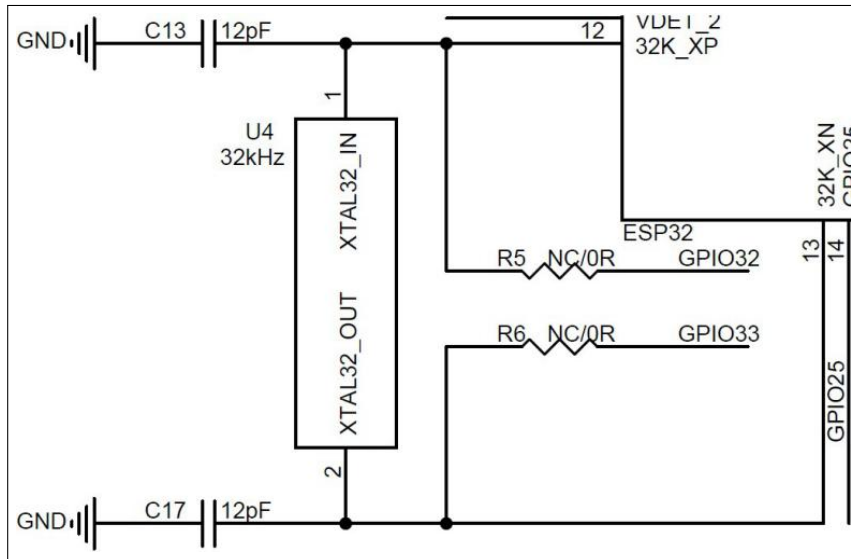

Figure 8: ESP32 Crystal Oscillator (RTC)

Notice:

If the RTC source is not required, then Pin12 32K_XP and Pin13 32K_XN can be used as digital GPIO pins.

3.1.5 RF

In the circuit design, a π -type matching network is essential for antenna matching.

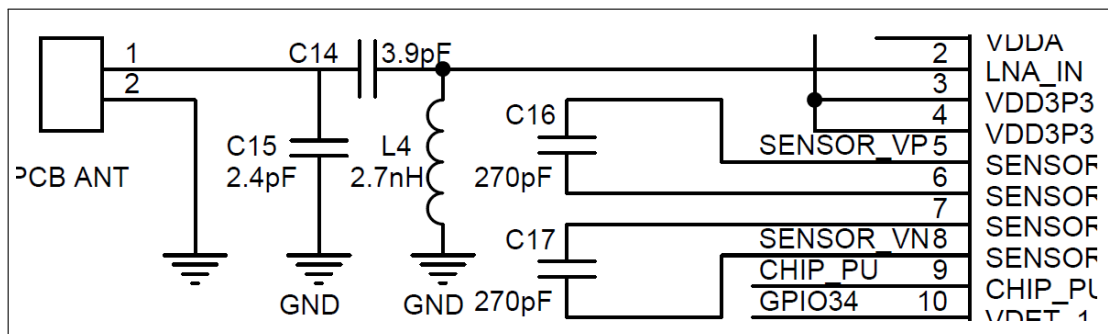

Figure 9: ESP32 RF Schematics

3.1.6 Sensor External Sampling Capacitor

The capacitors (270 pF) between SENSOR_VP and SENSOR_CAPP, SENSOR_CAPN and SENSOR_VN are used as the sampling capacitors for the internal switch amplifier. If the two capacitors are removed, SENSOR_VP, SENSOR_CAPP, SENSOR_CAPN and SENSOR_VN can be used as normal ADCs.

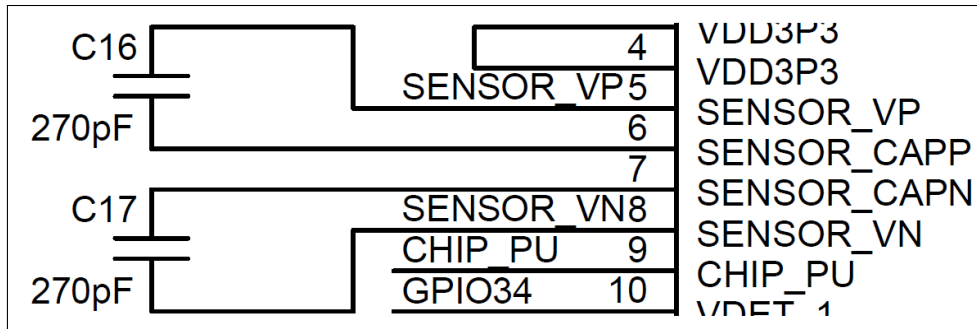

Figure 10: ESP32 Sensor External Sampling Capacitor

3.1.7 External Capacitor

The schematics of Pin47 CAP2 and Pin48 CAP1 is shown in Figure 11. C5 (10 nF) that connects to CPA1 should be of high precision. For the RC circuit between CAP1 and CAP2, please refer to Figure 11. Removing the RC circuit may slightly affect ESP32 in Deep-sleep.

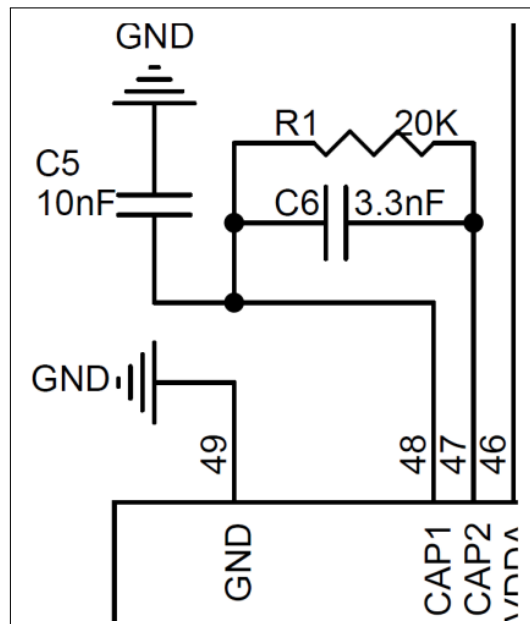

Figure 11: ESP32 External Capacitor

3.2 PCB Layout

The PCB layout design guidelines are applicable to cases when the

- ESP32 module functions as a standalone device, and when the
- ESP32 functions as a slave device.

3.2.1 Standalone ESP32 Module

3.2.1.1 General Principles of PCB Layout

We recommend a four-layer PCB design.

- The first layer is the TOP layer for signal traces and components.
- The second layer is the GND layer without signal traces being routed so as to ensure a complete GND plane.
- The third layer is the POWER layer. It is acceptable to route signal traces on this layer, provided that there is a complete GND plane under the RF and crystal oscillator.
- The fourth layer is the BOTTOM layer, where power traces are routed. Placing any components on this layer is not recommended.

3.2.1.2 Power Supply

The 3.3V power traces are highlighted in yellow in Figure 12. The width of these power traces should be larger than 20 mil. Before power traces reach the analog power-supply pins (Pin 1, 3, 4, 43, 46), a 0603 10 μ F capacitor and a 0402 0.1 μ F capacitor are needed. As Figure 12 shows, C13 (10 μ F capacitor) is placed by the 3.3V stamp hole, and C10 is placed close to the analog power-supply pin.

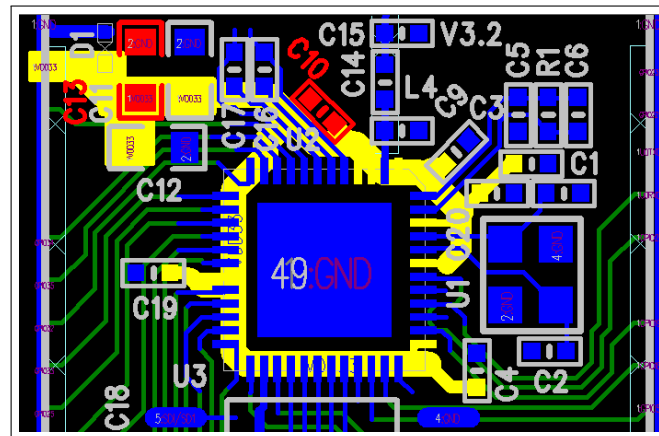

Figure 12: ESP32 PCB Layout

It is good practice to route the power traces on the fourth (bottom) layer. Vias are required for the power traces to go through the layers and get connected to the pins on the top layer. The diameter of the drill should exceed the width of the power traces. The diameter of the via pad should be 1.5 times that of the drill.

3.2.1.3 Crystal Oscillator

For the design of the crystal oscillator, please refer to Figure 13. In addition, the following should be noted:

- The crystal oscillator should be placed far from the clock pin. **The recommended gap is 2.7 mm.** It is good practice to add high-density ground vias around the clock trace for greater insulation.
- There should be no vias for the input and output traces, which means that the traces cannot cross layers.
- The external regulating capacitor should be placed on the near left or right side of the crystal oscillator and at the end of the clock trace.

- Do not route high-frequency digital signal traces under the crystal oscillator. It is best not to route any signal trace under the crystal oscillator. The larger the copper area on the top layer is, the better.
- As the crystal oscillator is a sensitive component, do not place any magnetic components nearby, such as a high-current inductor.

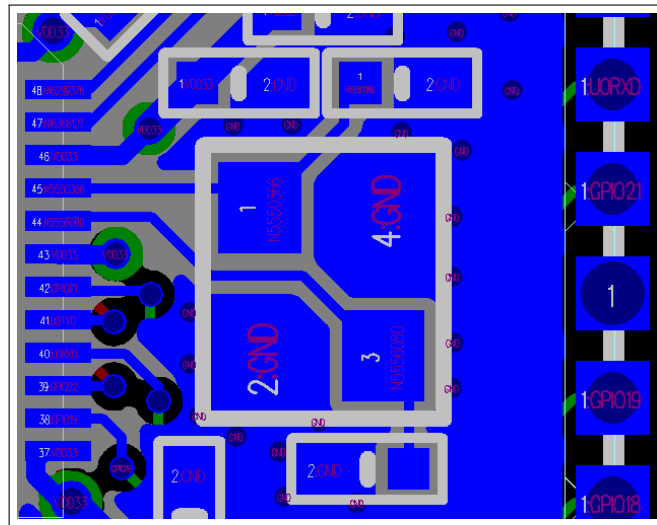

Figure 13: ESP32 Crystal Oscillator

3.2.1.4 RF

The characteristic RF impedance must be 50Ω . The ground plane on the adjacent layer needs to be complete. Make sure you keep the width of the RF trace consistent, and do not branch the trace. The RF trace should be as short as possible with vias around it for insulation.

However, there should be no vias for the RF trace. The RF trace should be routed at a 135° angle, or with circular arcs.

π -type matching circuitry should be reserved on the RF trace and placed close to the chip.

No high-frequency signal traces should be routed close to the RF trace. The RF antenna should be placed away from high-frequency transmitting devices, such as crystal oscillators, DDR, and clocks (SDIO_CLK), etc.

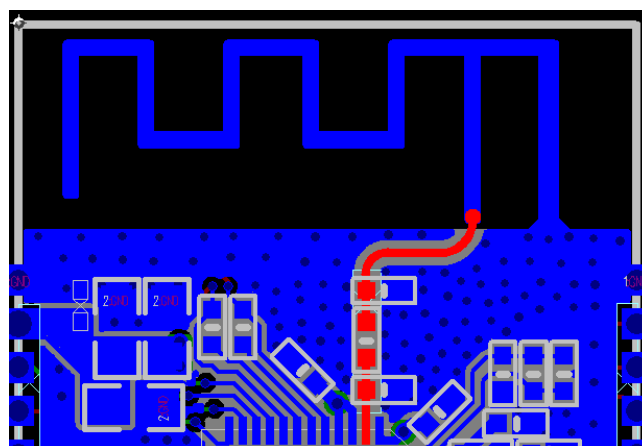

Figure 14: ESP32 RF

3.2.2 ESP32 as a Slave Device

When ESP32 works as a slave device, the user needs to pay more attention to signal integrity in the PCB design. It is important to keep ESP32 away from the interferences caused by the complexity of the system and an increased number of high-frequency signals. We use the mainboard of a PAD or TV Box as an example here to provide guidance on the PCB design.

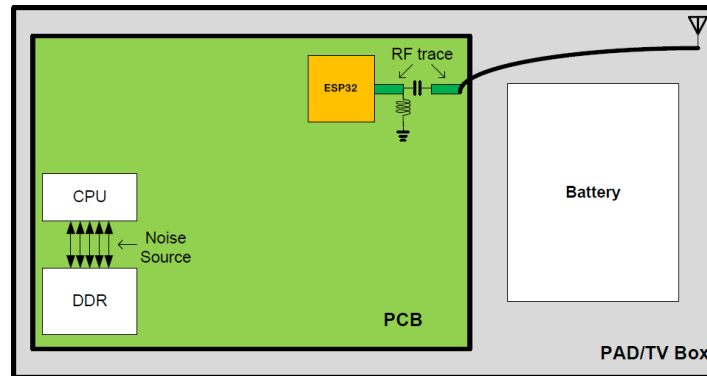

Figure 15: PAD/TV Box Layout

The digital signals between the CPU and DDR are the main producers of the high-frequency noise that interferes with Wi-Fi radio. Therefore, the following should be noted during the PCB design.

- As can be seen in Figure 15, ESP32 should be placed at the edge of the PCB and away from the CPU and DDR, the main noise sources. The distance between the chip and the noise sources decreases the interference and reduces the coupling noise.
- It is suggested that a 200Ω series resistor is added to the six signal traces when ESP32 communicates with the CPU via SDIO to decrease the drive current and any interferences, and also to eliminate the sequence problem caused by the inconsistent length of the SDIO traces.
- A PCB on-board antenna is not recommended, as it receives much interference and coupling noise, both of which impact the RF performance. We suggest that you use an external antenna which should be directed away from the PCB board via a cable, in order to weaken the high frequency interference with Wi-Fi.
- The high-frequency signal traces between the CPU and MEM should be routed strictly according to the routing guidelines (please refer to the DDR trace routing guidelines). We recommend that you add ground vias around the CLK traces separately, and around the data, or that you add traces in groups.
- The GND of the Wi-Fi circuit and that of other high-power devices should be separated and connected through wires if there are high-power components, such as motors, in the design.
- The antenna should be kept away from high-frequency noise sources, such as LCD, HDMI, Camera Sensor, USB, etc.

3.2.3 Typical Layout Problems and Solutions

3.2.3.1 Q: The current ripple is not large, but the Tx performance of RF is rather poor.

Analysis:

The current ripple has a strong impact on the RF Tx performance. It should be noted that the ripple must be tested when ESP32 is in the normal working mode. The ripple increases when the power gets high in a different mode.

Generally, the ripple should be <100 mV when ESP32 sends 11n MCS7 packets, and < 120 mV when ESP32 sends 11b 11m packets.

Solution:

Add a 10 μF filter capacitor to the branch of the power trace (the branch is ESP32's analog power pin). The 10 μF capacitor should be as close to the analog power pin as possible for small and stable current ripples.

3.2.3.2 Q: The power ripple is small, but RF Tx performance is poor.**Analysis:**

The RF Tx performance can be affected not only by power ripples, but also by the crystal oscillator itself. Poor quality and big frequency offsets of the crystal oscillator decrease the RF Tx performance. The crystal oscillator can be corrupted by other interfering signals, such as output or input signals. In addition, high-frequency signal traces, such as the SDIO trace and UART trace under the crystal oscillator, could also result in the malfunction of the crystal oscillator. Besides, sensitive components or radiation components, such as inductors and antennas, may also decrease the RF performance.

Solution:

This problem is caused by improper layout and can be solved by re-layout. Please see Chapter 3.2 for details.

3.2.3.3 Q: When ESP32 sends data packages, the power value is much higher or lower than the target power value, and the EVM is relatively poor.**Analysis:**

The disparity between the tested value and the target value may be due to signal reflection caused by the impedance mismatch on the transmission line between the RF pin and the antenna. Besides, the impedance mismatch will affect the working state of the internal PA, making the PA prematurely access the saturated region in an abnormal way. The EVM becomes poor as the signal distortion happens.

Solution:

Match the antenna's impedance with the reserved π -type circuit on the RF trace, so that the resistance of the RF pin towards the antenna is similar to that of the chip.

3.2.3.4 Q: Tx performance is not bad, but the Rx sensitivity is low.**Analysis:**

Good Tx performance indicates proper RF impedance matching. External coupling to the antenna can affect the Rx performance. For instance, the crystal oscillator signal's harmonics could couple to the antenna. If the Tx and Rx traces of UART cross over with RF trace, then, they will affect the Rx performance, as well. If ESP32 serves as a slave device, there will be other high-frequency interferences on the board, which may affect the Rx performance.

Solution:

Keep the antenna away from crystal oscillators. Do not route high-frequency signal traces close to the RF trace. Please see Chapter 3.2 for details.

4. Hardware Development

4.1 ESP-WROOM-32 Module

4.1.1 Overview

Espressif provides users with an SMD module, the ESP-WROOM-32. This module has been adjusted, in order to achieve the optimum RF performance.

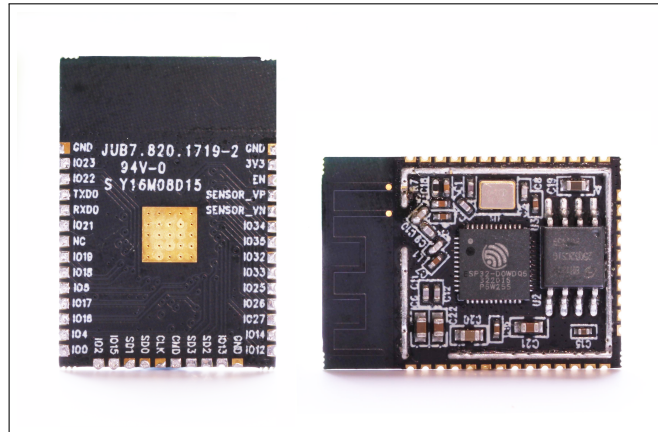

Figure 16: ESP-WROOM-32 Module

The size of the module is 18 mm x 25.5 mm. The flash used is an SOP8-208 mil one. The on-board PCB antenna has a gain of 2 dBi. Figure 17 shows the dimensions and pin layout of this module.

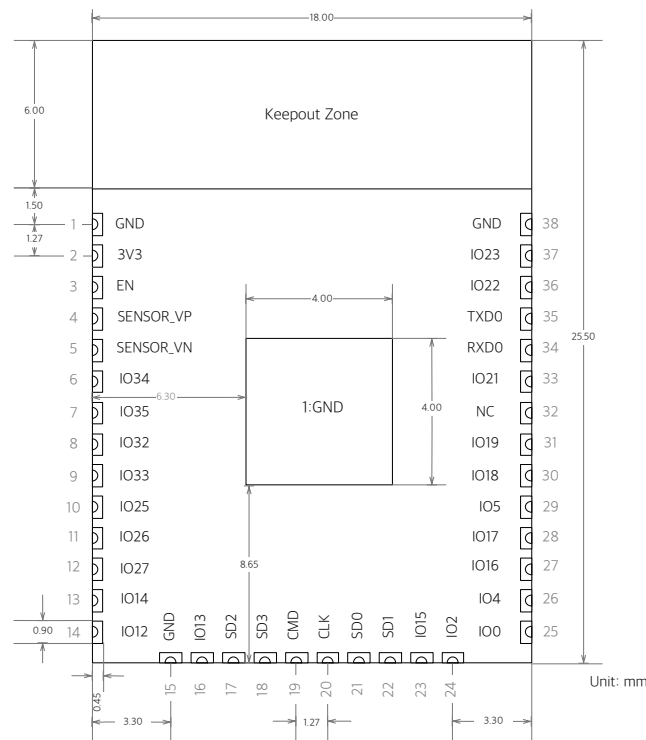

Figure 17: ESP-WROOM-32 Pin Layout

4.1.2 Pin Definition

There are 38 pins led out onto the module. The pin descriptions are listed in Table 3 below:

Table 3: WROOM-32 Pinouts

NO	Name	Function
1	GND	GND
2	3V3	3.3 V power supply (VDD)
3	EN	Chip enable pin. Active high.
4	SENSOR_VP	GPI36, SENSOR_VP, ADC_H, ADC1_CH0, RTC_GPIO0
5	SENSOR_VN	GPI39, SENSOR_VN, ADC1_CH3, ADC_H, RTC_GPIO3
6	IO34	GPI34, ADC1_CH6, RTC_GPIO4
7	IO35	GPI35, ADC1_CH7, RTC_GPIO5
8	IO32	GPIO32, XTAL_32K_P (32.768 kHz crystal oscillator input), ADC1_CH4, TOUCH9, RTC_GPIO9
9	IO33	GPIO33, XTAL_32K_N (32.768 kHz crystal oscillator output), ADC1_CH5, TOUCH8, RTC_GPIO8
10	IO25	GPIO25, DAC_1, ADC2_CH8, RTC_GPIO6, EMAC_RXD0
11	IO26	GPIO26, DAC_2, ADC2_CH9, RTC_GPIO7, EMAC_RXD1
12	IO27	GPIO27, ADC2_CH7, TOUCH7, RTC_GPIO17, EMAC_RX_DV
13	IO14	GPIO14, ADC2_CH6, TOUCH6, RTC_GPIO16, MTMS, HSPICLK, HS2_CLK, SD_CLK, EMAC_TXD2
14	IO12	GPIO12, ADC2_CH5, TOUCH5, RTC_GPIO15, MTDI, HSPIQ, HS2_DATA2, SD_DATA2, EMAC_TXD3
15	GND	GND
16	IO13	GPIO13, ADC2_CH4, TOUCH4, RTC_GPIO14, MTCK, HSPID, HS2_DATA3, SD_DATA3, EMAC_RX_ER
17	SHD/SD2	GPIO9, SD_DATA2, SPIHD, HS1_DATA2, U1RXD
18	SWP/SD3	GPIO10, SD_DATA3, SPIWP, HS1_DATA3, U1TXD
19	SCS/CMD	GPIO11, SD_CMD, SPICS0, HS1_CMD, U1RTS
20	SCK/CLK	GPIO6, SD_CLK, SPICLK, HS1_CLK, U1CTS
21	SDO/SD0	GPIO7, SD_DATA0, SPIQ, HS1_DATA0, U2RTS
22	SDI/SD1	GPIO8, SD_DATA1, SPID, HS1_DATA1, U2CTS
23	IO15	GPIO15, ADC2_CH3, TOUCH3, MTDO, HSPICS0, RTC_GPIO13, HS2_CMD, SD_CMD, EMAC_RXD3
24	IO2	GPIO2, ADC2_CH2, TOUCH2, RTC_GPIO12, HSPIWP, HS2_DATA0, SD_DATA0
25	IO0	GPIO0, ADC2_CH1, TOUCH1, RTC_GPIO11, CLK_OUT1, EMAC_TX_CLK
26	IO4	GPIO4, ADC2_CH0, TOUCH0, RTC_GPIO10, HSPIHD, HS2_DATA1, SD_DATA1, EMAC_TX_ER
27	IO16	GPIO16, HS1_DATA4, U2RXD, EMAC_CLK_OUT
28	IO17	GPIO17, HS1_DATA5, U2TXD, EMAC_CLK_OUT_180
29	IO5	GPIO5, VSPICS0, HS1_DATA6, EMAC_RX_CLK
30	IO18	GPIO18, VSPICLK, HS1_DATA7
31	IO19	GPIO19, VSPIQ, U0CTS, EMAC_TXD0

NO	Name	Function
32	NC	-
33	IO21	GPIO21, VSPIHD, EMAC_TX_EN
34	RXD0	GPIO3, U0RXD, CLK_OUT2
35	TXD0	GPIO1, U0TXD, CLK_OUT3, EMAC_RXD2
36	IO22	GPIO22, VSPIWP, U0RTS, EMAC_TXD1
37	IO23	GPIO23, VSPID, HS1_STROBE
38	GND	GND

4.1.3 Notes

- The module uses one single pin as the power supply pin. The user can connect the module to a 3.3V power supply. The 3.3V power supply works both for the analog circuit and the digital circuit.
- The EN pin is used for enabling the Wi-Fi functionality. Set the EN pin high for normal working mode.
- The SMD Module features two working modes: the UART Download mode and the Flash Boot mode. In the UART Download mode, firmware can be downloaded into the flash memory or the internal memory by configuring the flash download tool. If the firmware is burnt into the internal memory, it can only run this time when the module is powered on. Once the module is powered down, the internal memory will clear up. However, if the firmware is burnt into the flash, it will be stored and can be recalled at any time.
- Lead the GND RXD TXD pins out and connect them to a USB-to-TTL tool for firmware download, log-printing and communication.

By default the initial firmware has already been downloaded in the flash. If users need to re-download the firmware, they should follow the steps below:

1. Set the module to UART Download mode.
2. Pull IO0 and IO2 low.
3. Power on the module and check through the serial if the UART Download mode is enabled.
4. Download the firmware to flash using the ESP Flash Download Tool.
5. After downloading, keep IO15 low and pull IO0 high to enable the SPI Boot mode.
6. Power on the module again. The chip will read and execute the firmware during initialization.

Notice:

- During the whole process, users can check the status of the chip with the log printed through UART. If the firmware cannot be downloaded or executed, users can check if the working mode is normal during the chip initialization by looking at the log.
- The serial tool cannot be opened for both the log-print and flash-download tools simultaneously.
- Please download the ESP Flash Download Tool from Espressif's website: [Flash Download Tool](#).

4.2 ESP32-DevKitC

4.2.1 Overview

ESP32-DevKitC is a low-footprint, minimal system development board which is powered by our latest ESP-WROOM-32. The dimensions of the board are shown in Figure 18.

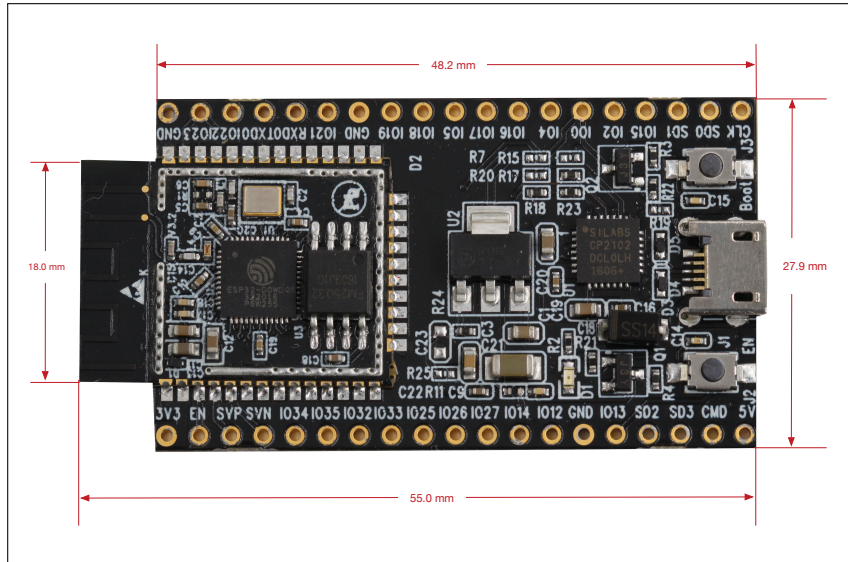

Figure 18: Top view of ESP32-DevKitC

All pins of ESP-WROOM-32 are led out to the pin headers on both sides for easy interfacing. ESP32-DevKitC features all the functions that are supported by ESP32. Users can connect these pins to peripherals as needed. The interfaces are shown in Figure 19. For more details, please see Section 4.1.2 ESP-WROOM-32 Pin Definition.

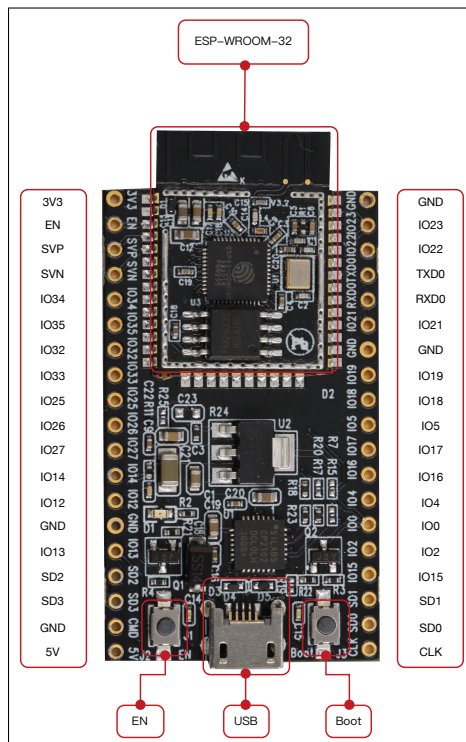

Figure 19: ESP32-DevKitC Pin Layout

4.2.2 Schematics

4.2.2.1 Power Schematics

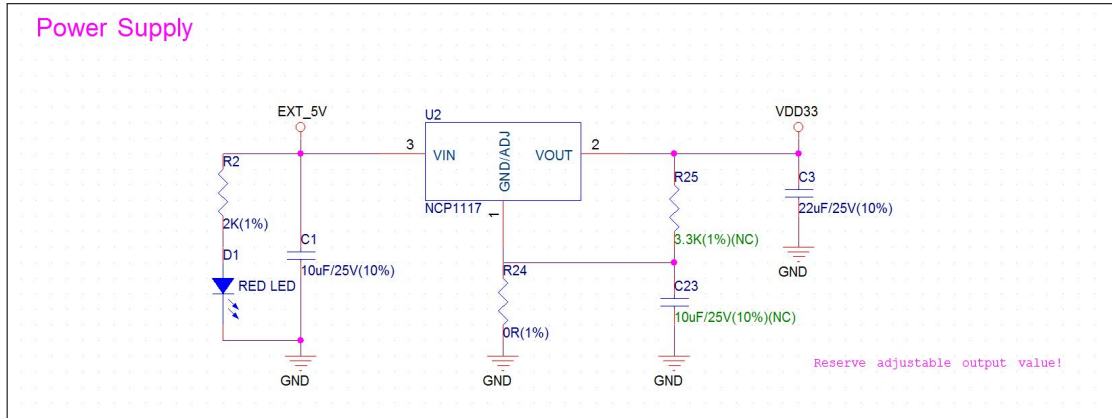

Figure 20: Power Schematics of ESP32-DevKitC

4.2.2.2 USB-UART Schematics

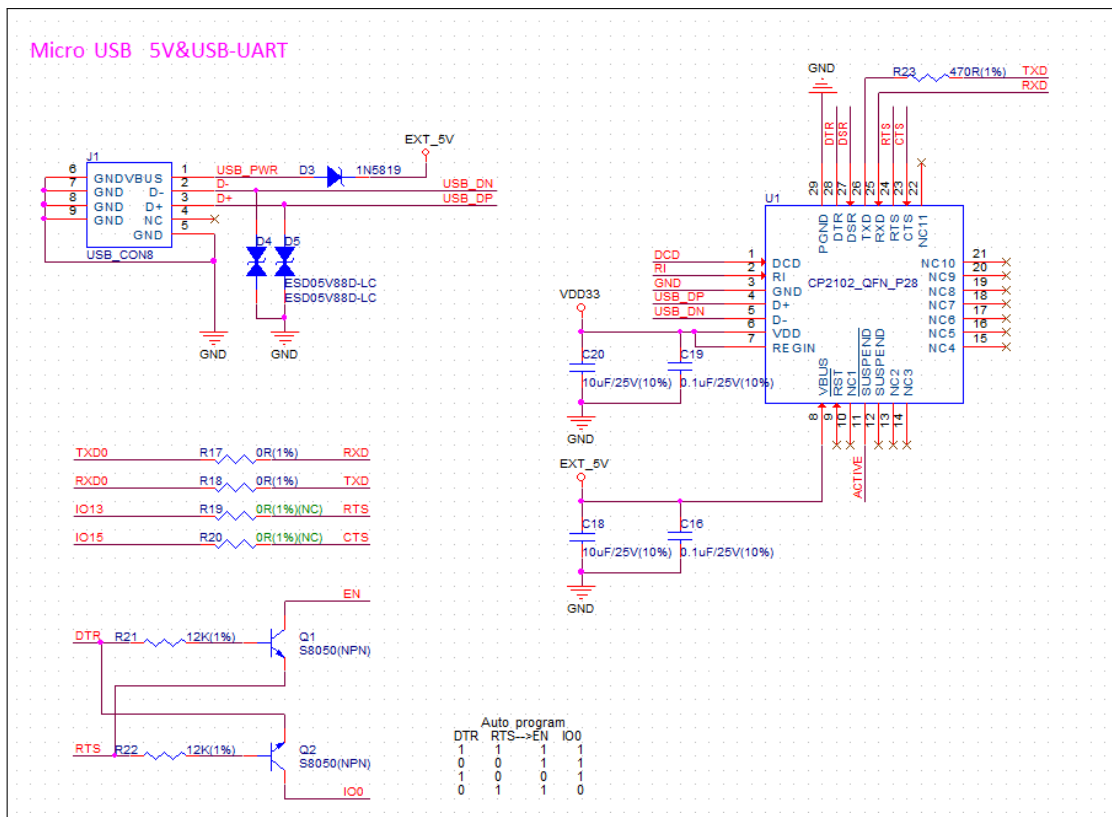

Figure 21: USB-UART Schematics

5. Applications

5.1 UART to Wi-Fi Smart Device

The two UART interfaces are defined in Table 4.

Table 4: Pin Definition of UART Interfaces

Categories	Pin Definition	Function
UART0	(Pin34) U0RXD + (Pin35) U0TXD	Used for printing logs.
UART1	(Pin17) U1RXD + (Pin18) U1TXD	Used for receiving and sending commands.

Application example: ESP32-DevKitC (please see Section 4.2 ESP32-DevKitC).

5.2 ESP32-Lyra Smart Audio Platform

ESP32-Lyra is a cost-effective smart audio platform, which is specifically designed by Espressif for the IoT industry. With its ESP32 dual-core processor and Wi-Fi + BT capability, ESP32-Lyra features voice recognition, audio playing, and access to cloud services. The ESP32-Lyra platform supports systems of artificial intelligence, voice and image recognition, wireless audio systems, as well as smart home networks.

The ESP32-Lyra Smart Audio Platform has the following features:

- Support for multiple audio interfaces with high extensibility
- Support for touch buttons
- Support for multiple audio formats including WMA, ALAC, AAC, FLAC, OPUS, MP3, WAV, and OGG
- Support for multiple wireless audio standards including DLNA, AirPlay and QPlay
- Support for multiple cloud platforms including Ximalaya FM, YunOS and Amazon
- Support for multiple distribution network protocols including ESP-TOUCH, ALINK, JoyLink3.0 and AirKiss